

ISM MD series

**INDOOR
CIRCUIT
MODULE**

15kV, ... 31.5kA, ... 1250A



TECHNICAL MANUAL

VERSION 3.1

Contents

1	Product description	5
1.1	Abbreviations	6
1.2	Main technical parameters	7
1.3	Disclaimers	12
1.4	Precautions	12
1.5	Warranty	12
2	Nameplates and seals	13
3	Product handling	18
3.1	Transportation	19
3.2	Storage	19
3.3	Unpacking and inspection	19
3.4	ISM and CM packaging and scope of supply	19
3.5	Optional kits scope of supply	23
3.6	Handling	29
4	Installation	30
4.1	Primary part	31
4.1.1	Preparation	31
4.1.2	Installation of the ISM	31
4.1.3	Main terminal connections of ISM15_MD_1, ISM15_MD_3	32
4.1.4	ISM15_MD_1, MD_3 interlocks	37
4.1.5	Installation of ISM15_MD_1, ISM15_MD_3 main contacts position indicator	46
4.1.6	Protective ground	49
4.2	Secondary part	51
4.2.1	Three-phase ISM secondary connections	51
4.2.2	Single-phase ISM secondary connections	52
4.2.3	CM secondary connections	53
4.2.4	Installation of the CM	54
4.2.5	Installation of secondary cables between ISM and CM	55
4.2.6	Auxiliary supply	57
4.2.7	CM indication	57
4.2.8	CM relay contacts operation	59
4.2.9	CM_16_1 Series Factory Programmable Options	60
4.2.10	CM_16_1 Series Operations counter reading	61
5	Commissioning	63
6	Operation	70
6.1	Switching	71
6.1.1	Closing	71
6.1.2	Opening	72
6.1.3	Emergency opening	72
7	Maintenance and troubleshooting	73
7.1	Primary circuits	74
7.2	Secondary circuits	76
7.3	Troubleshooting	77
8	Disposal	78
Appendix 1. ISM package dimensions and weights		80
Appendix 2: Overall Drawings		82
Appendix 3: Secondary Schemes		93
	List of changes	100

1 Product description

This User Manual describes Vacuum Circuit Breakers manufactured by Tavrida Electric.

Tavrida Electric MD circuit breakers are designed for rated voltage up to 15 kV.

Vacuum Circuit Breakers described in the current document can be used in a variety of switchgear and are intended to perform switching operations in network rated and faulty modes.

The breakers are comprised of following main components:

- Indoor Switching Module (ISM) - The ISM incorporates Tavrida Electric vacuum interrupters with monostable magnetic actuators and solid dielectric insulating materials. No SF-6 or oil insulation is used in the ISM;
- Control Module (CM) - The CM is a microprocessor based controller that provides ISM operation, protection and data logging functions;
- Kits - The kits of components are used to provide circuit breaker application properties.

This manual contains information on switching operations, required check-ups and maintenance, as well as service and disposal procedures. The purpose of the document is to provide necessary product information for users providing installation, commissioning and utilizing installed equipment.

1.1 Abbreviations

AC Actuator coil

AS Auxiliary switch

BIL Basic Insulation Level

EMC Electromagnetic compatibility

CM Control Module

CO Close - Open operations cycle

Com Common point of contact

I/O Input / Output

ISM Indoor Switching Module

LED Light emitting diode

(P)MCB Protective miniature circuit breaker

PS Position switch

NA Not applicable

NC Normally closed contact

NO Normally open contact

PCD Phase center distance

USB Universal Serial Bus

VCB Vacuum Circuit Breaker

VI Vacuum interrupter

1.2 Main technical parameters

Main technical data and circuit breaker technical parameters are presented in the tables below.

Table 1 - Main technical parameters

Type	ISM15_MD1	ISM15_MD3
Rated voltage (Ur)	15 kV	15 kV
Rated normal current (Ir)	1250 A	1250 A
Rated power frequency withstand voltage (Ud)	36 kV	36 kV
Rated lightning impulse withstand voltage (peak) (Up)	95 kV ¹⁾	95 kV ¹⁾
Rated short-circuit breaking current (Isc)	31.5 kA ²⁾	31.5 kA ²⁾
Rated peak withstand current (Ip)	82 kA	82 kA
Rated short-time withstand current (Ik)	31.5 kA	31.5 kA
Rated duration of short circuit (tk)	4 s	4 s
Rated frequency (fr)	50/60 Hz	50/60 Hz
Mechanical life (CO-cycles)	30 000	50 000
Maximum number of CO-cycles per hour	60	60
Operating cycles, rated–short circuit breaking current	50	50
Closing time	≤ 20 ms	≤ 25 ms
Opening time	≤ 8 ms	≤ 35 ms
Rated operating sequence at rated normal current	O-0.3s-CO-10s-CO-10s-CO ³⁾	
Rated operating sequence at rated short-circuit breaking current	O-0.3s-CO-15s-CO	
Auxiliary circuits insulation strength ⁴⁾		
Power frequency test voltage (1 min) according to IEEE C37.09	2.5kV	2.5kV
Insulation resistance, 1000V DC according to IEC60255-27	≥ 5 MOhm	≥ 5 MOhm
Standards	IEEE C37.09, C37.09a, C37.09b, C37.04	
Mechanical vibration withstand capability according to IEC 60721-3-4	Class 4M4	Class 4M4
Resistance of main circuit	≤ 17 μOhm	≤ 17 μOhm
Weight (depending on Phase center distance)	33-35 kg	13 kg
Altitude above sea level	1000 m ⁵⁾	1000 m ⁵⁾
Relative humidity in 24 hours	≤ 95 %	≤ 95 %
Relative humidity over 1 month	≤ 90 %	≤ 90 %
Temperature Range	-45°C...+55°C	-45°C...+55°C
Degree of protection according to IEC 60529 of actuator compartment	IP40	

Type	ISM15_MD1	ISM15_MD3
Service conditions	a) The ambient air is not polluted by dust, smoke, corrosive and/or flammable gases, vapors or salt and would be considered as having a site pollution severity class (SPS) "very light" according to IEEE C37.04 Table C.1. b) The average value of the water vapor pressure, over a period of 24 h, does not exceed 2.2 kPa. c) The average value of the water vapor pressure, over a period of one month, does not exceed 1.8 kPa.	
Type of driving mechanism	Monostable magnetic actuator	
Operation counter	Electrical, built in into control module	
Design, switching capacity of silver auxiliary contacts		
Number of available auxiliary contacts for three-phase ISM	Up to 6 NO + 6 NC	2 NO + 2 NC
Minimum current for 12 V AC / DC, ohmic load	100 mA	
Minimum current for 12 V AC / DC, inductive load (t=20 ms, cos ϕ =0,3)	100 mA	
Maximum current for 30 V DC, ohmic load	10 A ⁶⁾	
Maximum current for 30 V DC, inductive load (t=20 ms)	3 A	
Maximum current for 60 V DC, ohmic load	0.9 A	
Maximum current for 60 V DC, inductive load (t=20 ms)	0.9 A	
Maximum current for 125 V DC, ohmic load	0.5 A	
Maximum current for 125 V DC, inductive load (t=20 ms)	0.03 A	
Maximum current for 250 V DC, ohmic load	0.25 A	
Maximum current for 250 V DC, inductive load (t=20 ms)	0.03 A	
Maximum current for 125 V AC, ohmic load	10 A ⁷⁾	
Maximum current for 125 V AC, inductive load (cos ϕ =0,3)	5 A	
Maximum current for 250 V AC, ohmic load	10 A ⁷⁾	
Maximum current for 250 V AC, inductive load (cos ϕ =0,3)	5 A	
Design, switching capacity of gold-plated auxiliary contacts ⁶⁾		
Number of available auxiliary contacts for three-phase ISM	On request	
Minimum current for 5 V AC / DC	1 mA	
Maximum current for 10 V AC / DC	300 mA	
Maximum current for 30 V AC / DC	100 mA	
Maximum voltage AC / DC	30 V	
CM operation times		
Preparation time for the operation of the CM after switching on the auxiliary power supply	≤ 15 s	
Preparation time for the close operation of the CM after a previous close operation	≤ 10 s	
Preparation time for the trip operation of the CM after switching on the auxiliary power supply	≤ 0.1 s	
Trip capability after failure of the auxiliary power supply	≥ 60 s ⁸⁾	

1) Small dimensions of switching module may not provide necessary phase-to-ground clearance for every particular busbar connection. It is recommended to check BIL level of particular busbar connection in closed breaker position. Alternatively, a set of predesigned rubber insulation sleeves (cbkit_ins_4) may be used, which are preliminarily tested to provide the required BIL.

- 2) At 40% d.c. component.
- 3) The number of sequential Close-Trip operations with a 10 second interval should not exceed 10. The number of Close-Trip operations should not exceed 60 per hour. Sequence of 10s Close-Trip operations can be repeated only after 260 s pause.
- 4) Isolation resistance check is not applicable for "Actuator Coil" circuits of CM.
- 5) Up to an installation altitude of 1000 m above sea level. Above 1000m, the external insulation measurement of the ISM must be increased by the atmospheric correction factor K_a according to IEEE Std C37.100.1 compared to the insulation measurement at sea level. The maximum allowed altitude is 2000 m above sea level.
- 6) Gold-plated auxiliary contacts are available on request. Contact your nearest sales representatives.
- 7) At 5 min short-term duty. Continuous current – 5 A.
- 8) In case of Dry contacts "Close" and "Trip" are open.

Table 2 – CM Main Technical Parameters

Parameter	Value
CM operation times	
Preparation time for the operation of the CM after switching on the auxiliary power supply	≤ 15 s
Preparation time for the close operation of the CM after a previous close operation	≤ 10 s
Preparation time for the trip operation of the CM after switching on the auxiliary power supply	≤ 0.1 s
Trip capability after failure of the auxiliary power supply	≥ 60 s ¹⁾
CM supply voltage	
Rated range of supply voltage of CM_16_1(60_2)	24V to 60V DC
Rated range of supply voltage of CM_16_1(220_2)	110V to 220V AC/DC 50/60Hz for AC
Rated range of supply voltage of CM_16_2(220_2)	
Operating range (80-120%) of CM_16_1(60_2)	19V to 72V DC
Operating range (80-120%) of CM_16_1(220_2)	85V to 265V AC/DC 50/60Hz for AC
Operating range (80-120%) of CM_16_2(220_2)	
Power consumption of CM	
Charging the close and trip capacitors of CM_16_1(60_2)	≤ 25 W
Charging the close and trip capacitors of CM_16_1(220_2)	≤ 42 W AC ²⁾ ≤ 37 W DC
Charging the close and trip capacitors of CM_16_2(220_2)	
Permanent power consumption (standby) of CM_16_1(60_2)	≤ 5 W
Permanent power consumption (standby) of CM_16_1(220_2)	≤ 7 W AC ³⁾ ≤ 5 W DC
Permanent power consumption (standby) of CM_16_2(220_2)	
Inrush current of CM_16_1(60_2) with discharged capacitors	≤ 120 A
Inrush current of CM_16_1(220_2) with discharged capacitors	≤ 18 A
Inrush current of CM_16_2(220_2) with discharged capacitors	
Inrush time constant of CM_16_1(60_2) with discharged capacitors	≤ 0.5 ms
Inrush time constant of CM_16_1(220_2) with discharged capacitors	≤ 4 ms
Inrush time constant of CM_16_2(220_2) with discharged capacitors	
Design, Switching Capacity of CM Output Relays (Dry Contacts)	
Number of relays in CM_16_1	3
Number of relays in CM_16_2	
Number of available contacts for one relay	1 NO + 1 NC with common point
Rated voltage	240 V
Rated current AC	16 A
Maximum breaking power AC	4000 VA
Maximum switching current 250V DC	0.35 A
Maximum switching current 125V DC	0.45 A
Maximum switching current 48V DC	1.3 A
Maximum switching current 24V DC	12 A
Switching time	5 ms
Operations counter	10 digits, available via USB port
“Close” and “Trip” dry contacts inputs of CM	
Output voltage	≥ 30 V
Contacts closed current	≥ 50 mA
Steady state current	≥ 5 mA
Weight of CM_16_1	1 kg
Weight of CM_16_2	
Overall dimensions of CM ⁴⁾	190x165x45 mm
Temperature Range	-40°C...+55°C
Service conditions	a) The ambient air is not polluted by dust, smoke, corrosive and/or flammable gases, vapors or salt and would be considered as having a site pollution severity class (SPS) “very light” according to IEEE C37.04 Table C.1. b) The average value of the water vapor pressure, over a period of 24 h, does not exceed 2.2 kPa. c) The average value of the water vapor pressure, over a period of one month, does not exceed 1.8 kPa.

Parameter	Value
CT Power Supply Parameters (for CM_16_2(220_2) only)	
Operating current range	2-300 A
Power consumption per phase during charging trip capacitors	
- 2 A	5 VA
- 5 A	12 VA
- 10 A	25 VA
- 30 A	120 VA
- 300 A	8 kVA
Preparation time for trip operation (charging of the trip capacitor), no more than	
- 2 A	1000 ms
- 5 A	400 ms
- 10 A	150 ms
- 30 A	110 ms
- 300 A	100 ms
Current carrying capacity, not less than	
- 2 A	∞
- 5 A	100 s
- 10 A	10 s
- 30 A	1 s
- 300 A	0.1 s
Environmental Conditions: Location, ordinary dry	
Maximum operating temperature	55°C
Maximum operating altitude	2000 m
Maximum humidity, no more	98 % (no condensation)

- 1) In case of Dry contacts "Close" and "Trip" are open.
- 2) At $\cos \varphi > 0.66$.
- 3) At $\cos \varphi > 0.33$.
- 4) Overall dimensions of ISM are given in "Appendix 3. Overall drawings"

1.3 Disclaimers

Tavrida Electric will not accept any claims for damages caused by improper transport, storage or unpacking. Transport damage must be reported in writing to the supplier as soon as it is discovered.

The Technical manual contains information necessary for installation, commissioning and operation. It is absolutely necessary to read the Technical manual carefully and to adhere to the instructions and relevant regulations. Tavrida Electric will not accept any claims for damages caused by improper usage of the Vacuum Circuit Breakers. In case of special configurations please contact Tavrida Electric prior of usage of the Vacuum Circuit Breakers.

1.4 Precautions

- Check whether the installation position (distances, spatial separation, and the surroundings) is suitable for the switching devices.
- Installation, operation and maintenance shall only be carried out by trained and experienced personnel who are familiar with the equipment and the electrical safety requirements.
- During installation, commissioning, operation and maintenance of the equipment the relevant legal regulations, accident prevention regulations and the connecting conditions of the electric utilities shall be followed.
- Take note that during operation of the Vacuum Circuit Breakers certain parts are subject to dangerous voltage. Mechanical parts, also remote-controlled, can move quickly. Failure to comply may result in death, severe personal injury or damage to equipment.
- Pay attention to the hazard statements located throughout this Technical manual.
- The operating conditions of the vacuum circuit breakers shall comply with the technical data specified in this Technical manual.
- Personnel installing, operating and maintaining the equipment shall be familiar with this Technical manual and its contents.

1.5 Warranty

Unless otherwise stated in the contract, the warranty period is stated in Standard warranty policy. If agreed to otherwise, the contract conditions apply. No warranty is given in the case of ...

- a) ... the warranty period having run out during the period of storage with the customer;
- b) ... the operating conditions, ambient conditions, transport and storage conditions have not been adhered to according to the application description or the Installation and Operating Instructions;
- c) ... an unauthorized manipulation of the device has been carried out, such as opening the housing or damaging the seal;
- d) ... the device has not been properly installed, such as incorrect connection of supply voltage of auxiliary circuits.

2 Nameplates and seals

The Vacuum Circuit Breakers itself does not have nameplates or seals but main components (ISM, CM and manual generators) do.

ISM nameplates and seals

Each ISM has the following plate and labels:

- Label
- Serial number plate
- Seals

TYPE: ISM15_MD_1(150)			
Rated maximum voltage	15 kV	Rated cont. current	1250 A
Rated impulse voltage	95 kV	Rated S-C current	31.5 kA ¹
Rated dielectric withstand	42 kV	DC component	40%
Power frequency	60 Hz	Short time current	31.5 kA / 4 s
Peak cap.bank energizing current	3000 A ²	Interrupting time	See user manual
Cable charging brk. current	31.5 A	Pole centre distance	150 mm
Year manufactured	2024	Weight	33 kg
Instruction book number		TENA_VCB15-25_TM_MD_EN	
¹ Tested with reference DC component referred to time constant 45 ms. See control module for duty cycle. ² Contact your representative for details.			
Conforms to: ANSI C37.04, ANSI C37.06, ANSI C37.09, CSA C22.2#31 MVT ELEKTRİK SANAYİ VE TİCARET LİMİTED ŞİRKETİ EGE SERBEST BÖLGESİ ŞUBESİ Zafer SB Mah. Defne Sok. No:3 İç Kapı No:1 Gazıemir, 35410 İzmir - TURKEY www.magvatech.com Made in Turkey			

Figure 1
ISM label

The serial number plate contains information about ISM type and serial number.

The label contains brief information about ISM technical parameters.

There are warranty seal labels on each side of the ISM metal frame.

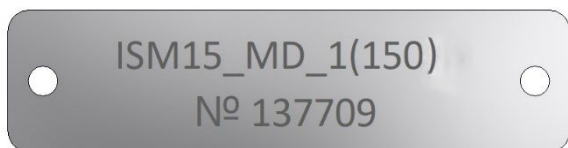

Figure 2
Serial number plate

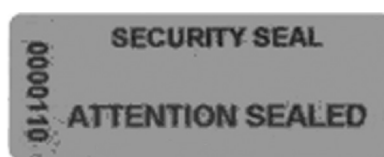

Figure 3
Warranty seal

Label, seal and serial number plate arrangement is shown below



1. Serial number plate
2. Label
3. Seal

Figure 4
Serial number and designation label arrangement

CM_16_1 nameplates and seals

Each CM_16_1 has the following labels:

- Serial number label
- Information label with terminals connections and main parameters
- Information label with settings code for CM_16_1 modules
- Seals



Figure 5
Serial number label

FACTORY SETTINGS CODE: 10-00-160-245-1212-11	UNDERVOLTAGE RELEASE SETTINGS UV On/Off: OFF UV Delay: 0 Seconds Reclose on UV: 0 Reclose Delay: N/A	DIGITAL OUTPUTS Relay 1: Breaker Position Relay 2: Ready Status Relay 3: Malfunction Status	TRIP / CLOSE SETTINGS Trip Delay: 12 ms Close Delay: 12 ms Trip Input: N/O Dry Contact Close Input: N/O Dry Contact
USE WITH BREAKER TYPES: ISM15_MD_1	Settings for this device have been pre-installed by Tavrida engineering services. Refer to the appropriate ISM user manual for detailed information or contact Tavrida at 1-866-551-8362		

Figure 6
Information Label With Settings Code For CM_16_1 Modules

Power Supply Input
 [85...265]V AC/DC 50/60Hz
 25VA for 10s (charging)
 7.5VA steady state

Fault/Ready Relays
 Max 240VAC, 16A
Operating Duty
 O-0.3s-CO-10s-CO-10s

Operating Conditions
 -40C to +55C ambient
 IP40 degree of protection



Conforms to
 UL 61010-1
 Certified to
 CAN/CSA-C22.2
 #61010-1

**Tavrída Electric
 North America**
 1-866-551-8362
 www.tavrída-na.com
 Made in Turkey

* - See side label for settings code.
 ** - See label above for firmware code.

⚠ See applications manual for required input power protection, required type, gauge and insulation class of connected wires and for output relays DC load break capacity. See side label for control settings data.

⚠ AVERTISSEMENT		⚠ WARNING
Risque de choc électrique. Débrancher l'alimentation avant la maintenance. Pour éviter les risques de choc électrique, ne pas toucher les bornes lorsque un ou des voyants sont allumés.		Risk of electric shock. Disconnect the electric power before servicing. To avoid electrical shock do not touch terminals while any indicator is lit.

X1	X2	X3																																										
<table border="1"> <tr> <td>POWER 1</td><td>POWER 2</td><td>RELAY 1.1</td><td>RELAY 1.2</td><td>RELAY 1.3</td><td>RELAY 2.1</td><td>RELAY 2.2</td><td>RELAY 2.3</td><td>RELAY 3.1</td><td>RELAY 3.2</td><td>RELAY 3.3</td><td>CLOSE 1</td><td>CLOSE 2</td><td>TRIP 1</td><td>TRIP 2</td> </tr> <tr> <td>1</td><td>2</td><td>3</td><td>4</td><td>5</td><td>6</td><td>7</td><td>8</td><td>9</td><td>10</td><td>11</td><td>12</td><td>13</td><td>14</td><td>15</td> </tr> </table>	POWER 1	POWER 2	RELAY 1.1	RELAY 1.2	RELAY 1.3	RELAY 2.1	RELAY 2.2	RELAY 2.3	RELAY 3.1	RELAY 3.2	RELAY 3.3	CLOSE 1	CLOSE 2	TRIP 1	TRIP 2	1	2	3	4	5	6	7	8	9	10	11	12	13	14	15	<table border="1"> <tr> <td>CT 1.1</td><td>CT 1.2</td><td>CT 2.1</td><td>CT 2.2</td> </tr> <tr> <td>1</td><td>2</td><td>3</td><td>4</td> </tr> </table>	CT 1.1	CT 1.2	CT 2.1	CT 2.2	1	2	3	4	<table border="1"> <tr> <td>COIL 1</td><td>COIL 2</td> </tr> <tr> <td>1</td><td>2</td> </tr> </table> <input type="radio"/> POWER <input type="radio"/> MALFUN <input type="radio"/> READY	COIL 1	COIL 2	1	2
POWER 1	POWER 2	RELAY 1.1	RELAY 1.2	RELAY 1.3	RELAY 2.1	RELAY 2.2	RELAY 2.3	RELAY 3.1	RELAY 3.2	RELAY 3.3	CLOSE 1	CLOSE 2	TRIP 1	TRIP 2																														
1	2	3	4	5	6	7	8	9	10	11	12	13	14	15																														
CT 1.1	CT 1.2	CT 2.1	CT 2.2																																									
1	2	3	4																																									
COIL 1	COIL 2																																											
1	2																																											

Figure 7
 Information Label with Terminals Connections and Main Parameters

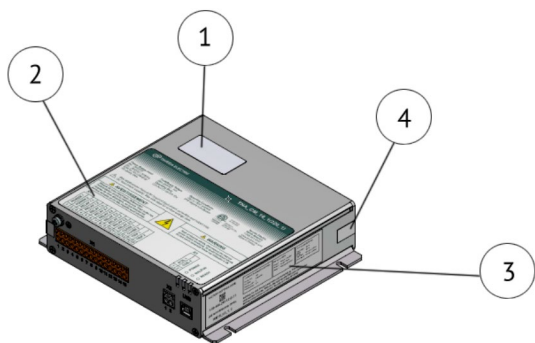

1. Serial Number Label
2. Information Label with Terminals Connections and Main Parameters Warning Label
3. Information Label with Settings Code for CM_16_1 Modules
4. Warranty Seal

Figure 8
 CM labels

Manual generator nameplates

Each manual generator has the following labels:

- Designation label
- Serial number label



Figure 9
Designation label

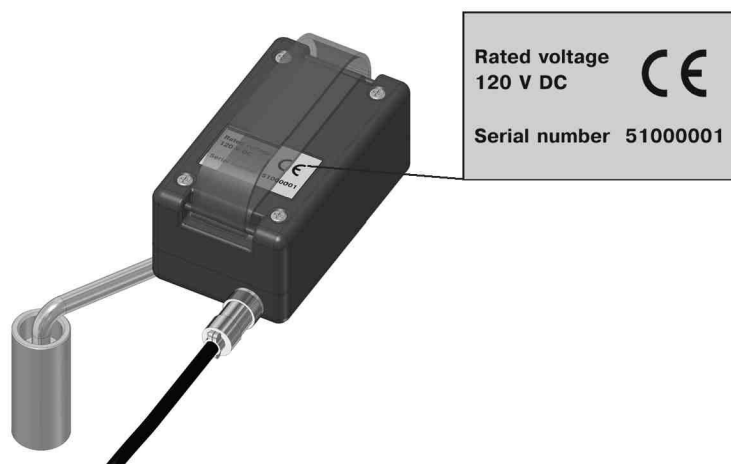

Figure 10
Serial number label

3 Product handling

3.1 Transportation

The ISMs are transported in the original packing only. Any kind of transport and combinations thereof are applicable. Transportation shall be provided in waterproof compartments. If air transport is used all products shall be transported inside heated, pressurized compartments. The packed goods shall be handled in accordance with the handling symbols. Loading procedures for ISM packaging shall be carried out only with use of fork lifts, hoists or cranes. If possible the packaged ISM shall be placed on a pallet. During transportation the ISM must not be subjected to sharp impacts or dropped.

3.2 Storage

If immediate installation is not possible, the ISM shall be stored in the original packing under the following conditions:

- the ISM is switched off (main contacts in the open position);
- desiccant must be placed in the packaging;
- storage must be dry, well ventilated and the room temperature should be between - 40°C and + 55°C.

Average humidity measured over 1 year period shall not exceed 75% at 50°C. If several ISMs are stacked a maximum of two vertical layers are permitted

In case the storage term exceeds one year from the production date it is recommended to perform the procedure of CM's electrolytic capacitor conditioning:

- apply power to the CM for 20 seconds;
- switch off the power supply and wait for 60 seconds;
- repeat the above actions 2 times;
- apply power to the CM continuously for 8 hours.

This procedure shall be performed annually during storage of the CM.

3.3 Unpacking and inspection

ISM unpacking and check

Before unpacking, check the carton for damage. Removal of the products from the original packaging must be carried out with care and in accordance with lifting procedures. Every ISM and CM component is supplied with the routine test certificate. Unloading procedures for ISM shall be carried out only with use of hoists or cranes. Lifting gear must not be attached to the support insulators. To lift the breaker, attach M12 ringbolts to the upper terminals (B or A and C) of the MD breaker and lift the breaker by the attached ringbolts.

All items should be checked visually for:

- mechanical damage, scratches, discoloration, corrosion;
- damage to the seals Figure 3.

Any transport damage must be reported immediately to the carrier in writing. Damages shall be photographically documented.

3.4 ISM and CM packaging and scope of supply

ISM packaging and scope of supply

The ISMs are placed in cardboard boxes (Figure 13):

- handling symbols label for transport and storage of the delivery unit (Figure 11);
- labels for manufacturers and product information (Figure 14);
- label for logistics data (Figure 12).

The ISM and CM scope of supply is presented in Appendix 1.

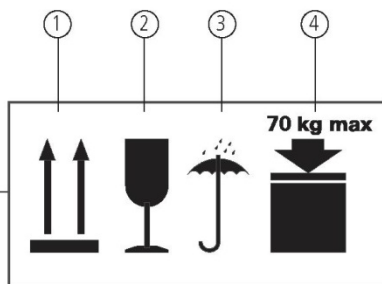

1. This side up
2. Fragile
3. Protect from rain
4. Max. weight on the delivery unit

Figure 11
Label 1 Handling symbols



Figure 13
Carton box

TAVRIDA ELECTRIC	
Mark:	TEG-C-000111
	Place of delivery:
Consignee:	Address
	Address
	Address
	Address
	Phone:
	Contact person
P/O Number:	Customer reference
Article:	Article description
Serial Number:	111999/16402484
<small>TAVRIDA ELECTRIC GmbH, Im Leimen 14, 88069 Tetttnang/Tannau, Germany, Phone: 0049-7542-946785-1</small>	

Figure 12
Label 2 Logistics data



TAVRIDA ELECTRIC	
Item number:	
	<small>8126V.L11118</small>
Designation:	TES_VCB15_MD1_16.F(1_2_1_1_1_1_1_2_2)
Description:	Circuit breaker
Gross weight:	39,5, kg
Serial number:	
	<small>111999/16402484</small>

Figure 14
Label 3 for manufacturers' and product information

ISM has in its package:

1. Indoor Switching Module (ISM);
2. Control Module (optional: can be delivered inside of the ISM package or in the individual carton box);
3. Additional kits and/or components (if applicable);
4. Routine test certificate of ISM.

The ISM shall have undamaged warranty seals (appearance of seal is shown in Figure 3, its placement on the ISM (there are two warranty seals on each side of the ISM metal frame) - in Figure 4). The ISM designation and serial number shall comply with data in the ISM routine test certificate (appearance of serial number plate is shown in Figure 2, its placement on ISM - in Figure 4).

Each of ISM15_MD_1, ISM15_MD_3 is supplied with the following components:

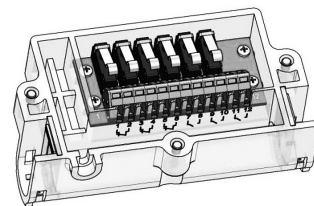

- a) ISM
- b) screwdriver Unit_Screwdriver_1
- c) auxiliary switches board

Figure 15
ISM15_MD_1 scope of supply

TNA_ISM15_MD_1 is supplied with 2 x CBkit_ASboard_2(3S). This includes 6 x NO (52a) and 6 x NC (52b) auxiliary contacts (3NO+3NC on each board). Other options are available on request – see Table 3.

Table 3 - CBkit_ASboard_2 parameters description

Parameter	Parameter description	Applicable options	Code
Par1	Auxiliary switches board type	3NO+3NC, silver plated	3S
		4NO+4NC, silver plated	4S
		6NO+6NC, silver plated	6S



- a) ISM
- b) screwdriver Unit_Screwdriver_1

Figure 16
ISM15_MD_3 scope of supply

CM_16_1 packaging and scope of supply

CM is packed and delivered in cardboard boxes. The CM cardboard box can be delivered separately from the ISM or be included in the ISM package.



Figure 17
CM packaging

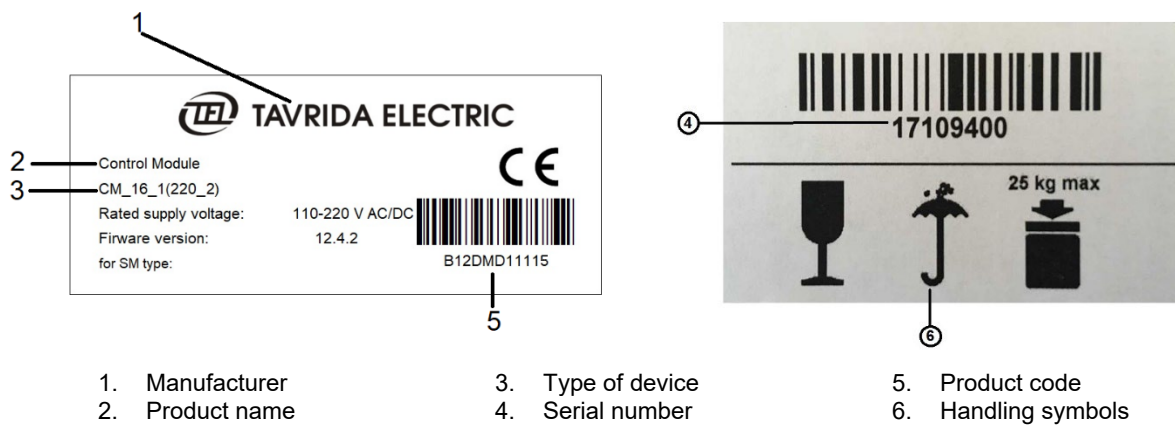

Figure 18
CM packaging labels

The CM_16_1 shall have undamaged warranty seals (its placement on the CM is shown in Figure 8). The CM settings code and serial number shall comply with data in the CM routine test certificate (appearance of the CM_16_1 serial number label and settings code label are shown in Figure 5 and Figure 6, their placement on the CM_16_1 – in Figure 8).

Each CM is supplied with the following components:



a) CM



b) screwdriver

Figure 19
CM_16_1 scope of supply

3.5 Optional kits scope of supply

CBkit_Ins_4 scope of supply

CBkit_Ins_4 provides the dielectric strength of busbars connection to the ISM15_MD_1 and ISM15_MD_3. The kit has components for one pole, so three such kits are necessary for one ISM15_MD_1 insulation and one – for ISM15_MD_3. The kit is delivered separately and packed in a plastic bag.

The kit includes one variant of the following options depending on the parameter value:



Rubber insulator CBdet_RubberIns_2
(for bars 40x10 mm) - 2 pcs.

Figure 20

CBkit_Ins_4(1) scope of supply



Rubber insulator CBdet_RubberIns_3
(for bars 80x10 mm) - 2 pcs.

Figure 21

CBkit_Ins_4(2) scope of supply

CBkit_Interlock_3 packaging and scope of supply

CBkit_Interlock_3 can be used with ISM15_MD_1, ISM15_MD_3 as an accessory for manual trip / lockout of the ISM by key switch. The kit is packed in a cardboard box.



Figure 22
CBkit_Interlock_3 packing

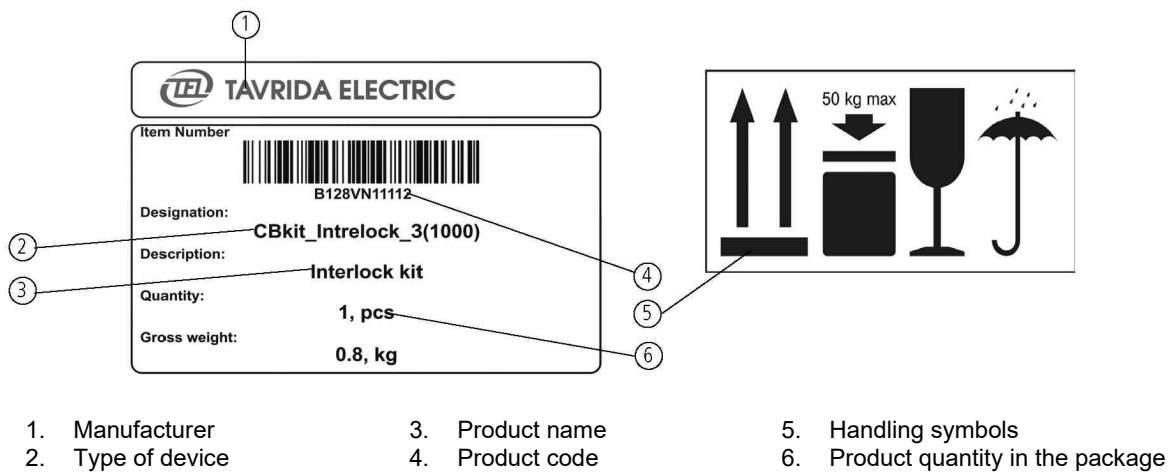
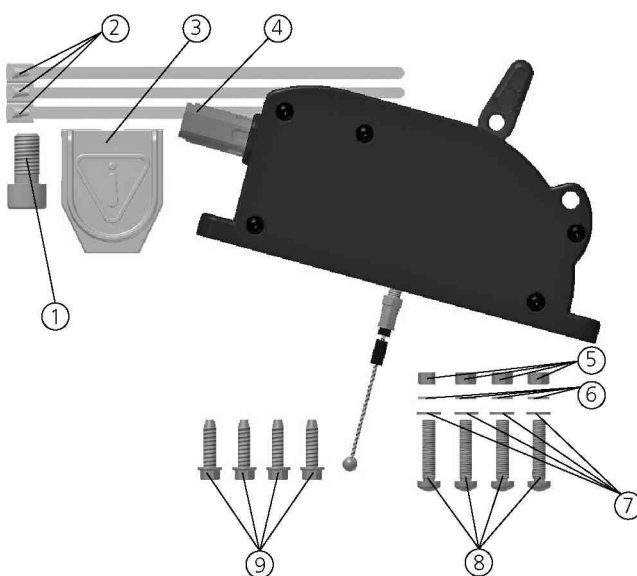

Figure 23
CBkit_Interlock_3 package labeling

The kit includes:



1. Screw StandDet_Screw_DIN912(M10_20_Fe88-Zn)
2. Cable tie StandDet_CableTie_LS(4.6_150_40)
3. Stopper CBdet_Stopper_2
4. Interlock unit CBunit_Interlock_1(1)
5. Nut StandDet_Nut_DIN555(M5_Fe-Zn)
6. Washer StandDet_Washer_DIN127-A (5_Fe-Zn)
7. Washer StandDet_Washer_DIN125-1A (5.3_Fe-Zn)
8. Screw StandDet_Screw_DIN7985-Ph (M5_25_Fe48-Zn)
9. Screw StandDet_Screw_DIN7504-K (4.8_19_Fe-Zn)

Figure 24
CBkit_Interlock_3 scope of supply

CBkit_Interlock_4 packaging and scope of supply

CBkit_Interlock_4 can be used with the ISM15_MD_1, ISM15_MD_3 as an accessory for manual trip / lockout of the ISM by rotary switch. The kit is packed in a cardboard box.



Figure 25
CBkit_Interlock_4 packing

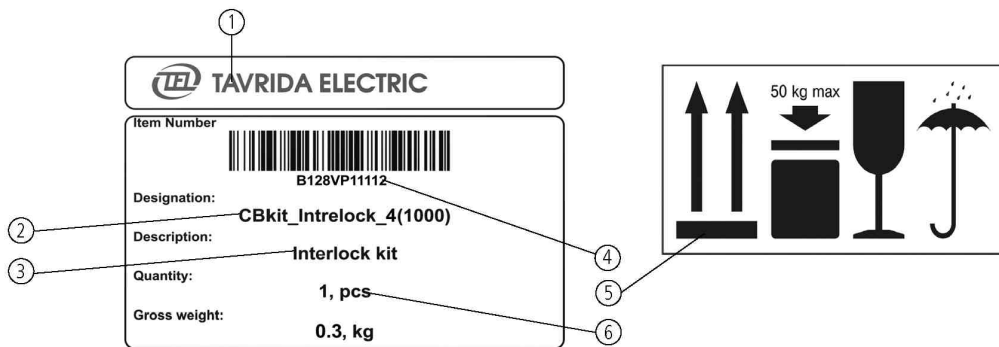

- | | | |
|-------------------|-----------------|------------------------------------|
| 1. Manufacturer | 3. Product name | 5. Handling symbols |
| 2. Type of device | 4. Product code | 6. Product quantity in the package |

Figure 26
CBkit_Interlock_4 package labeling

The kit includes:

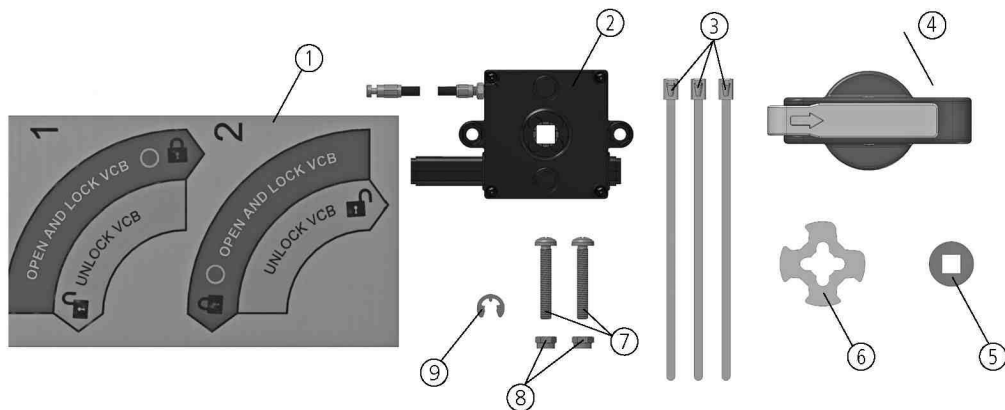

- | | |
|---|---|
| 1. Label CBdet_Label_10(EN) | 5. Washer CBdet_Washer_7 |
| 2. Interlock unit CBunit_Interlock_12(1) | 6. Stopper CBdet_Stopper_28 |
| 3. Cable tie StandDet_CableTie_LS(4.6_150_40) | 7. Screw StandDet_Screw_DIN7985-Ph (M6_40_Fe8-Zn) |
| 4. Handle CBunit_Handle_1 | 8. Nut StandDet_Nut_DIN985(M6_Fe8-Zn) |
| | 9. Washer StandDet_Washer_DIN6799(7_Fe-Zn) |

Figure 27
CBkit_Interlock_4 scope of supply

CBkit_Interlock_5 packaging and scope of supply

CBkit_Interlock_5 can be used with the ISM15_MD_1, ISM15_MD_3 as an accessory for manual trip of the ISM as a manual trip button. The kit is packed in a cardboard box.



Figure 28
CBkit_Interlock_5 packing

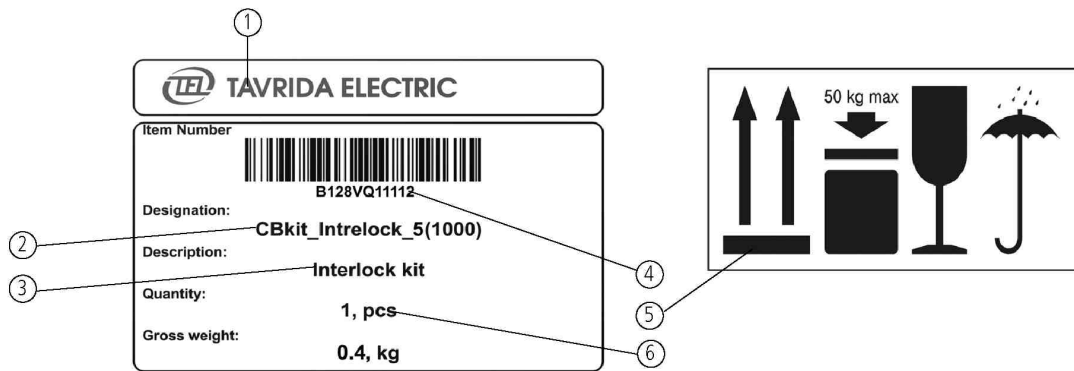

- | | | |
|-------------------|-----------------|------------------------------------|
| 1. Manufacturer | 3. Product name | 5. Handling symbols |
| 2. Type of device | 4. Product code | 6. Product quantity in the package |

Figure 29
CBkit_Interlock_5 package labeling

The kit includes:

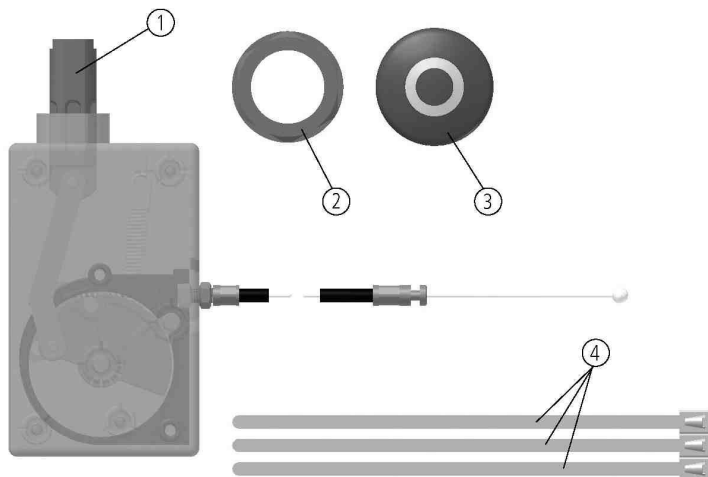

1. Manual trip unit
CBunit_ManualTrip_1(1000)
2. Plastic nut
StandDet_PlastNut_1(M25_gr)
3. Handle CBunit_Handle_2
4. Cable tie
StandDet_CableTie_LS(4.6_150_40)

Figure 30
CBkit_Interlock_5 scope of supply

CBkit_PosInd_1 packaging and scope of supply

CBkit_PosInd_1 is used to indicate the ISM main circuit position. The position indicator is packed in a plastic bag.

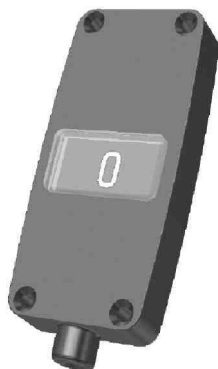

Figure 31

CBkit_PosInd_1 scope of supply

CBcomp_RelCable_3 packaging and scope of supply

CBcomp_RelCable_3 is a flexible trip and lock cable used for connection of ISM manual trip or interlock connection to the ISM. The cable is packed in a plastic bag.

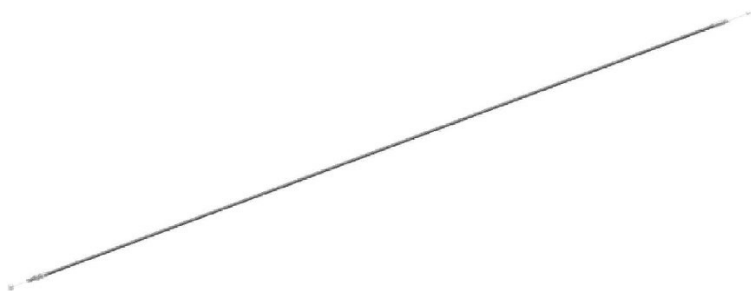

Figure 32

CBcomp_RelCable_1 scope of supply

CBunit_ManGen_1 and CBunit_ManGen_2 packaging and scope of supply

CBunit_ManGen is used to charge the CM in cases where the main auxiliary power supply is not available. It is packed in a cardboard box.

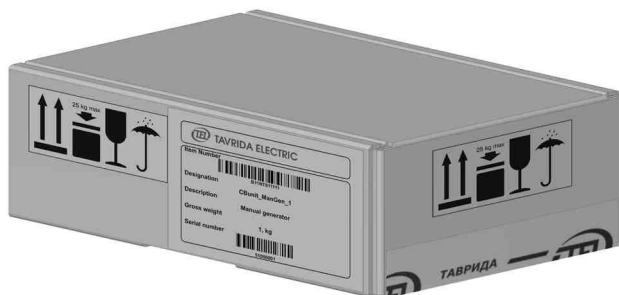
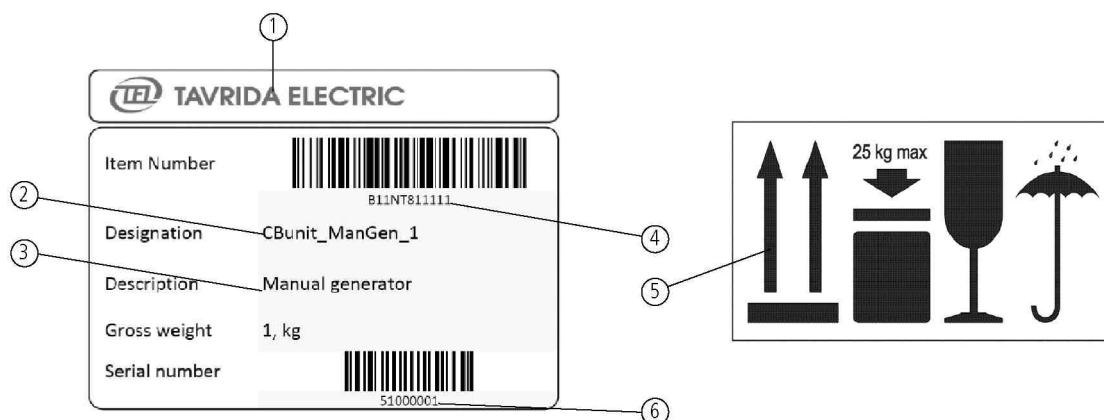

Figure 33
CBunit_ManGen_1 and CBunit_ManGen_2 packing



- | | | |
|-------------------|-----------------|---------------------|
| 1. Manufacturer | 3. Product name | 5. Handling symbols |
| 2. Type of device | 4. Product code | 6. Serial number |

Figure 34
CBunit_ManGen_1 package labeling



Figure 35
CBunit_ManGen_1 and CBunit_ManGen_2 scope of supply

3.6 Handling

To avoid equipment damage follow the handling recommendations listed below:

1. handling in accordance with pictorial symbols;
2. elimination of drops from any heights;
3. elimination of any mechanical impacts which can cause damage of the package;
4. the boxes are to be stowed to ensure complete tightness. The boxes should be hitched and lashed tightly so that it could not shift inside of a container under any conditions of carriage;
5. the modules shall be tied up with 16 mm polyester band twice. Top edges of the boxes shall be protected with plastic corners. The boxes can be additionally wrapped with stretch film.

4 Installation

4.1 Primary part

4.1.1 Preparation

All applicable regulations must be adhered to during installation, commissioning and operation, including ANSI, IEEE, CEC, NEC, and other local, national or international standards / codes as required. Work shall only be performed by qualified personnel.

Wearing of gloves for handling the parts during installation is recommended. Insulating material surfaces must be cleaned with clean and dry rags. The contact surfaces of connections must be cleaned before installation. If the contacts have become oxidized during transport or storage, then the following actions must be followed:

- Clean contact surfaces with a rough, dry cloth;
- In case of hard oxidation, clean with a hard plastic sponge, the coating layer must not be removed;

The nuts, washers and conical spring washers shall be used for connecting the terminals of the ISM with the busbars.

If additional fastening material is required, steel bolts according to EN ISO 898 class 8.8 (yield point 800 N/mm²), nuts according to EN ISO 890 class 8 (yield point 880 N/mm²), washers to DIN 125, and high load conical spring washers (#431540 in Schnorr catalogue - for ISM15_MD) shall be used. ISM mounting and shall be made with a calibrated torque wrench only.

4.1.2 Installation of the ISM

Mounting

In any switchgear application ISM15_MD can be installed in any position (Horizontal or Vertical).

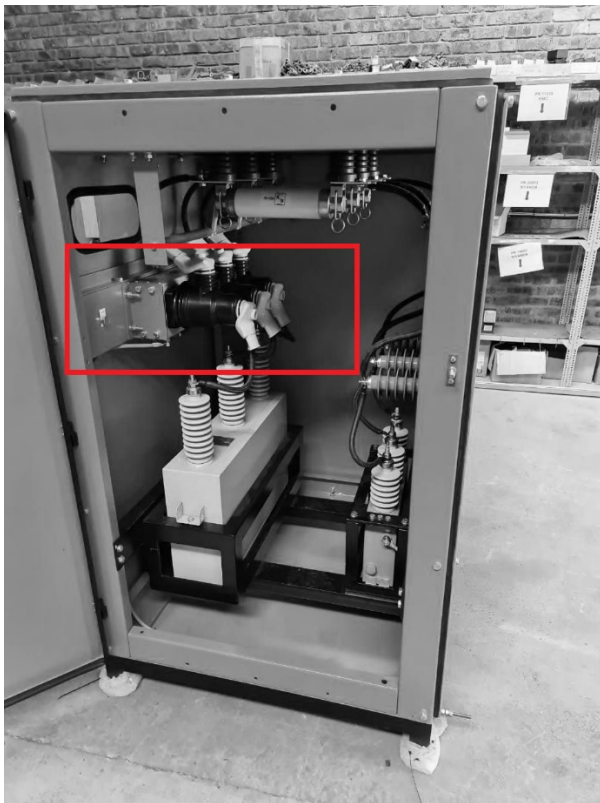
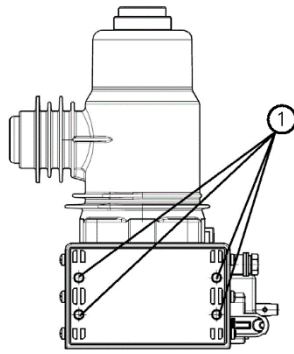

Figure 36

Withdrawable unit with ISM15_MD_1, tilted arrangement

Busbars and cables shall be connected with the ISM primary terminals mechanically in a stress-free manner. No pressure, tension or torsion forces shall act on the ISM. To avoid high mechanical loads on the ISM, the busbar connections shall be supported by additional insulators.

Calibrated torque wrenches shall be used for mounting of switching modules and the connection of busbars. Points shown below should be used for mounting the ISM.



1. Eight threads on both sides of the frame for obligatory ISM fixing (M10, torque is 25 ± 3 Nm).

Figure 37

ISM15_MD_1 mounting points

Ensure that the frame to which the ISM will be fixed does not create static load to the switching module.

4.1.3 Main terminal connections of ISM15_MD_1, ISM15_MD_3

Primary terminals connection

To comply with the rated impulse withstand voltage according to IEEE C37.09 one of the insulation kits for ISM15_MD_1 or ISM15_MD_3 may require (see table 4 below):

Table 4 - Insulation of ISM15_MD_1 main terminals

PCD, mm	BIL, kV	Busbars	Insulation kit
150	75	40x10 mm	Not required
	95		CBkit_Ins_4(1)
210	75	40x10 mm 80x10 mm	Not required
	95	40x10 mm 80x10 mm	CBkit_Ins_4(1) CBkit_Ins_4(2)

Note: Selection of single or double bars 40x10 mm depends on the rated normal current of ISM application.

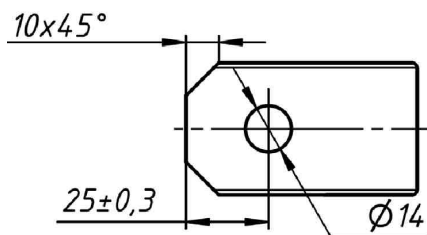

Figure 38

Edges of bars 40x10 mm at the place to ISM terminal connection

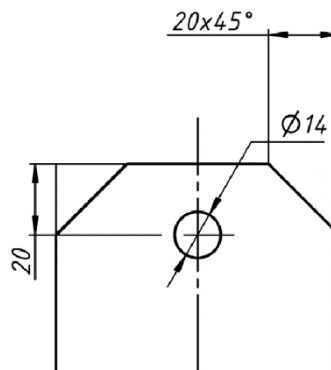

Figure 39

Edges of bars 80x10 mm at the place to ISM terminal connection

M12 bolts fixing busbars (or contact arms) to ISM15_MD_1 or ISM15_MD_3 terminals should be tightened with a torque of 50 ± 2 Nm.

If insulation kit is not used compliance with the rated insulation level shall be verified by a voltage test.

To prevent static load on the ISM poles it is not allowed to fasten busbars to the ISM terminal if there is a gap of more than one millimeter between the busbar and the ISM terminal just before this fastening. Bars shall be accurately prepared to avoid bending and (or) twisting forces to terminals when these bars are fastened.

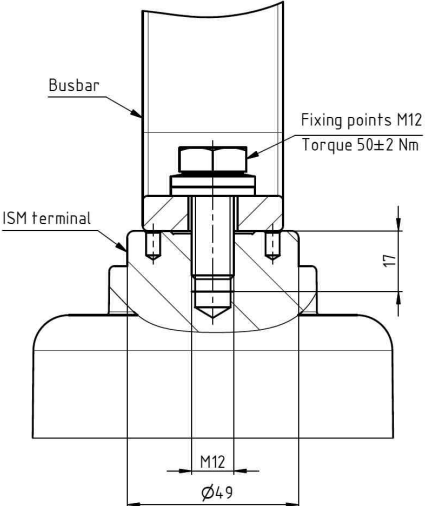

Figure 40
Details of ISM15_MD terminals connection to rectangular cross-shaped busbars (at fixed installation, for example)

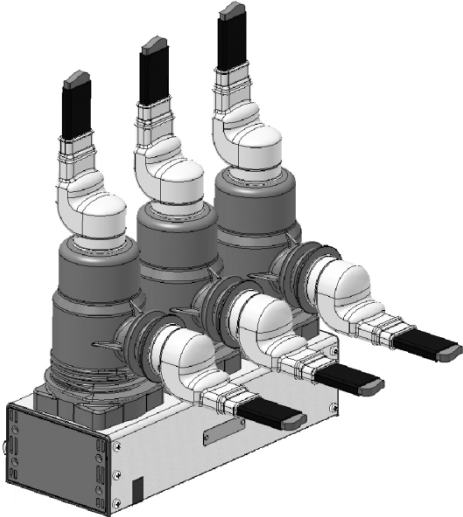

Figure 41
Details of ISM15_MD terminals connection to rectangular cross-shaped busbars with help of CBkit_Ins_4(1) (at fixed installation, for example)

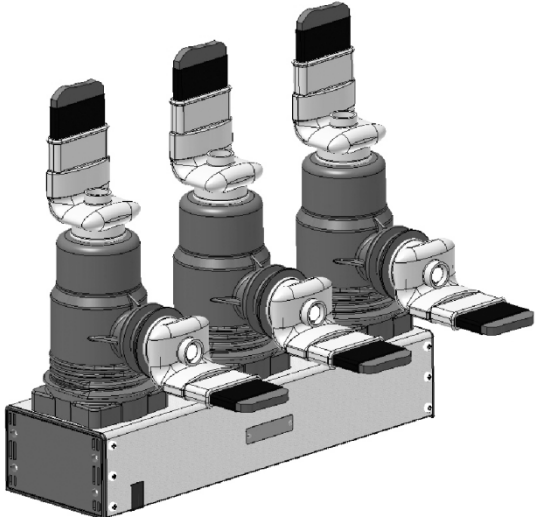

Figure 42
Details of ISM15_MD terminals connection to rectangular cross-shaped busbars with help of CBkit_Ins_4(2) (at fixed installation, for example)

Electrodynamic forces clearances

To avoid unacceptable high electrodynamic impact on the ISM, additional support insulators are required if the unsupported busbars are longer than specified in the Table 5.

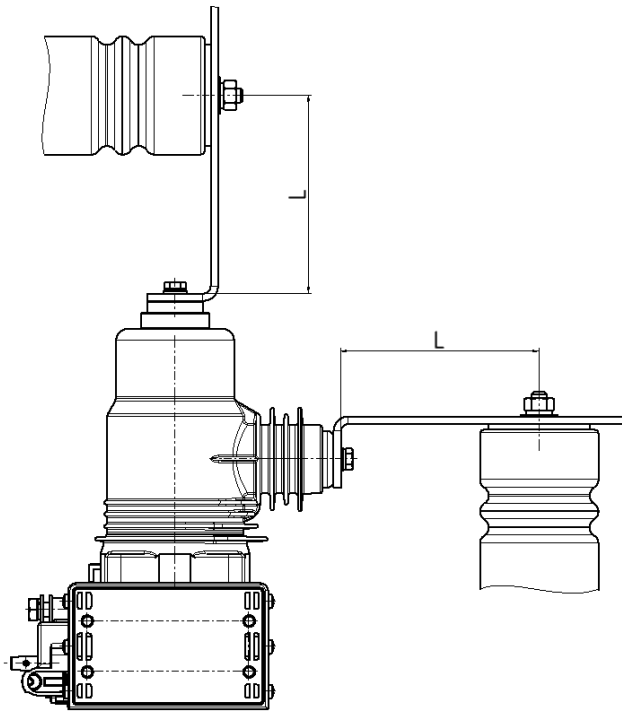

Figure 43

ISM support insulators installation distance

Table 5 - Additional support insulators installation minimum distances

ISM	Short-circuit current		
	20 kA	25 kA	31.5 kA
	L, mm		
ISM15_MD_1 with 150 mm PCD	700	450	300
ISM15_MD_1 with 210 mm PCD	980	630	420
ISM15_MD_3 ¹⁾	930	600	400
ISM15_MD_3 ²⁾	1100	820	500

¹⁾ In case ISM15_MD_3 is installed close to the other ISM15_MD_3.

²⁾ In case ISM15_MD_3 is installed separately from other ISM15_MD_3.

Electromagnetic clearances

To avoid primary current effect on ISM actuator, the minimum clearance between busbars and the ISM frame (Figure 44) should be no less than stated in the Table 6.

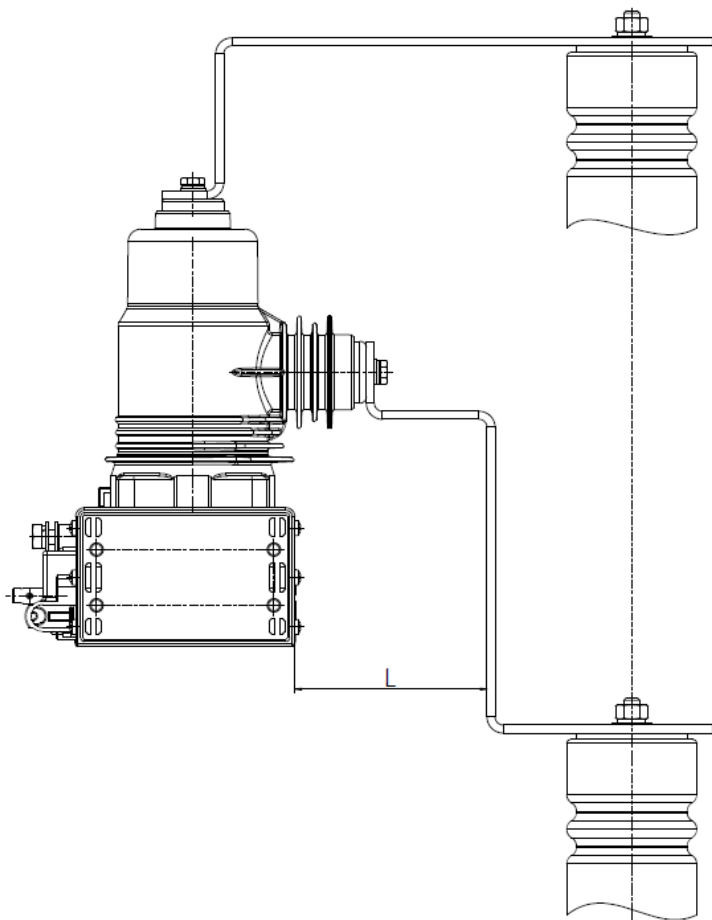

Figure 44
Electromagnetic clearances

Table 6 - Electromagnetic clearances

Short circuit current	Minimum clearance (L)	Applicable for
≤20 kA	100 mm	ISM15_MD_1
	100 mm	ISM15_MD_3
25 kA	120 mm	ISM15_MD_1
	120 mm	ISM15_MD_3
31.5 kA	150 mm	ISM15_MD_1
	150 mm	ISM15_MD_3

Insulation clearances

The recommended minimum phase-to-phase and phase-to-ground air clearances are stated in Table 7. Shorter distances shall be verified by a voltage test.

Table 7 - Insulation clearances

Power frequency rated voltage	Impulse test voltage (BIL)	Minimum clearance (L2)
5kV	60kV	120mm
15 kV	95 kV	140 mm

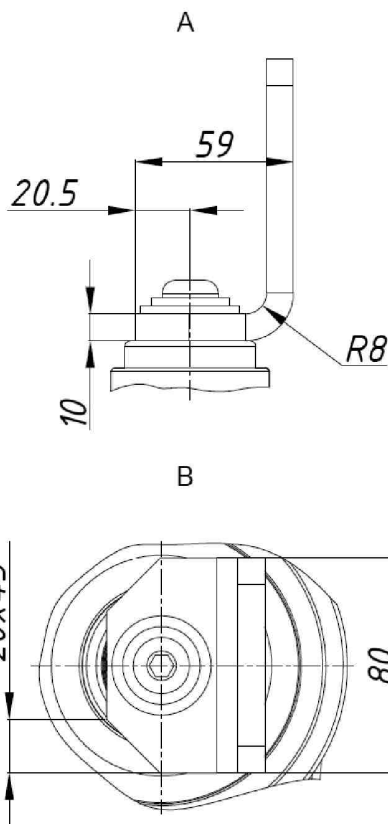
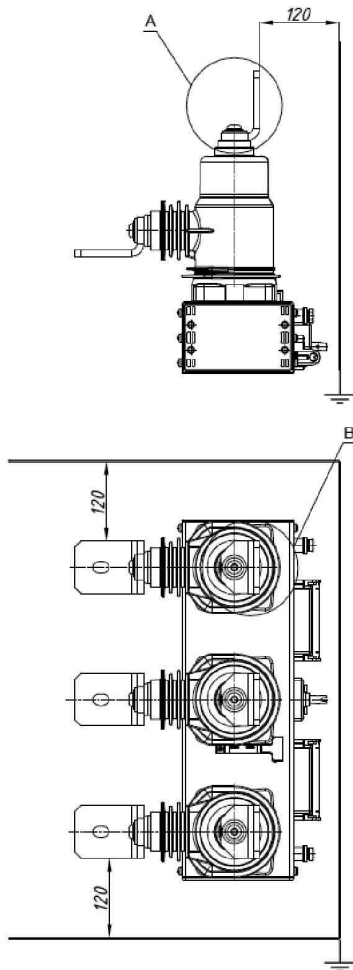

Figure 45
ISM15_MD insulation clearances - 60 kV BIL, 5 kV rated voltage application

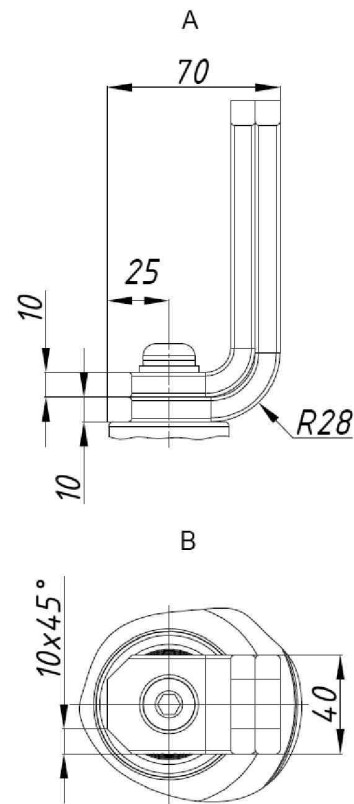
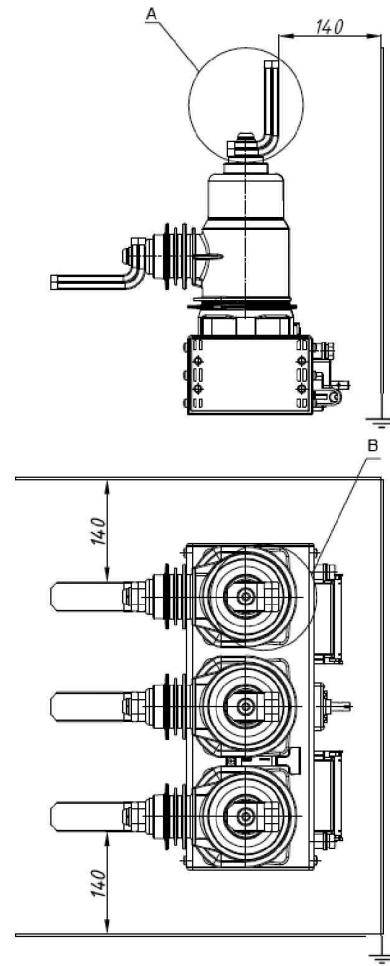

Figure 46
ISM15_MD insulation clearances - 95 kV BIL, 15 kV rated voltage application

Coordination of minimum clearances

Based on electromagnetic influence and rated insulation voltage, the largest value clearance should be selected.

4.1.4 ISM15_ MD_1, MD_3 interlocks

Interlocking mechanism

Each of ISM15_ MD_1, MD_3, is equipped with an interlocking shaft that can be rotated clockwise to the "unlatched" position or counter-clockwise to the "open and locked" position. In the "unlatched" position the ISM can perform "close" and "open" operations.

In the "open and locked" position the ISM the interlocking shaft prevents the actuator mechanically from closing. In addition the actuator coils are disconnected from the CM.

If the ISM is closed, rotation of the interlocking shaft from "unlatched" to "open and locked" position leads to manual tripping. The CM indicates alarm "Manual Trip".

The interlocking shafts of ISM15_ MD_1, MD_3 are not fixed in the "open and locked" position since these ISMs have a shaft return spring that returns them back to the "unlatched" position. To leave the shafts in the "open and locked" position the external force shall be applied to the shaft to hold it in this position as shown in Figure 48.

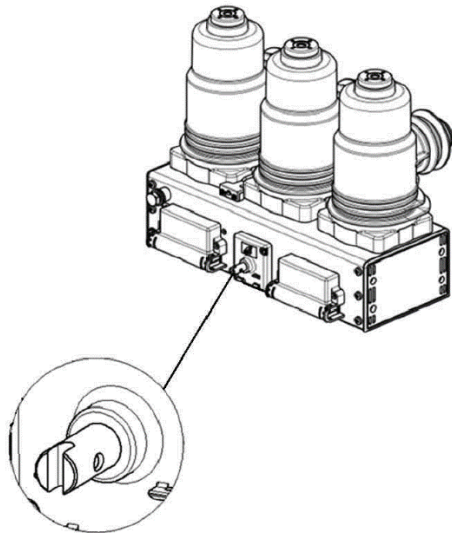
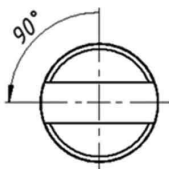

Figure 47
ISM15_MD_1 interlocking shaft

Open, locked



Unlocked

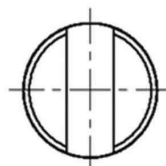
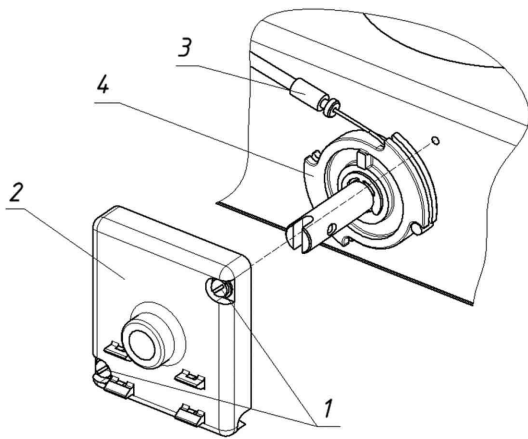

Figure 48
Interlocking shaft positions

Mechanical interlocking of ISM15_ MD_1, ISM15_ MD_3 can be performed by the remote interlocking unit. It connects with switching module via release cable. Follow the instructions below to install it:



1. Unscrew two captive screws 1;
2. Take off the plastic cover 2;
3. Install release cable 3 in cam 4 as show below;
4. Put the plastic cover back and tighten two screws 1.

Figure 49

Release cable connection to the interlocking shaft of ISM15_MD_1, ISM15_MD_3

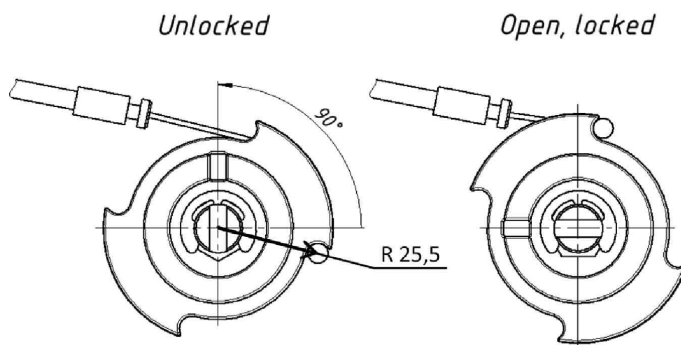

Figure 50

Interlocking shaft of ISM15_MD_1, MD_3 operation by release cable

The release cable operating stroke is $37 \pm 0,5$ mm, which is equal 90 degrees rotation angle of cam as shown in the Figure 48. Minimal bend radius for cable is 100 mm.

There is a possibility to install two remote interlocks which can operate independently of each other. For ISM15_MD_1, ISM15_MD_3 interlocking shaft torque is as follows:

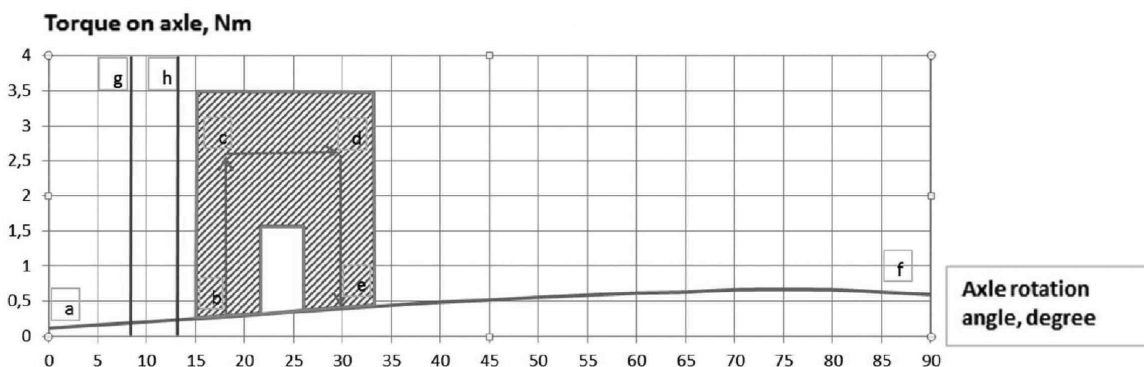

Figure 51

ISM15_MD interlocking shaft torque

The interlocking process might be divided into next steps:

- “a-b” – backlash;
- “b-c” – blocker contacts the magnetic actuator plate;
- “c-d” – blocker interacts the magnetic actuator plate;
- “d-e” – switching module turns off;
- “e-f” – switching module turns to “open and locked” position (point “f”);

- “f-a” – turning switching module to “unlatched” position (point “a”).
- “g-h” -- electrical interlock action.

The allowed deviations are indicated by hatching.

Torque on the interlocking shaft for ISM manual trip

The torque on the interlocking shaft for ISM manual trip shall be no more than 3.5 N*m for ISM15_MD_1 and ISM15_MD_3;

Load capacity of ISM15_MD_1, ISM15_MD_3 interlocking shaft

- The angle of the interlocking shaft rotation shall not exceed 90 °.

Exceeding any of the above limitations can lead to damage of the interlocking mechanism.

Connection of CBkit_Interlock_3 to ISM15_MD_1, ISM15_MD_3 interlocking shaft

CBkit_Interlock_3 can be used with the ISM15_MD_1, ISM15_MD_3 as an accessory for manual trip / lockout of the ISM by key switch.

The connection of the CBkit_Interlock_3 to the ISM15_MD_1, ISM15_MD_3 interlocking shaft is shown below. (Figure 52 – Figure 53). The ISM shall be in Unlatched position.

Notes:

- the bending radius of the flexible release cable shall be not less than 100 mm;
- it is recommended to install ISM in the Switchgear and connect its auxiliary circuits prior interlock connection to simplify the connection and adjustment process;
- if the flexible release cable passes through the Switchgear segregations according to the design solution it is recommended to pass it through these segregations prior interlock connection.

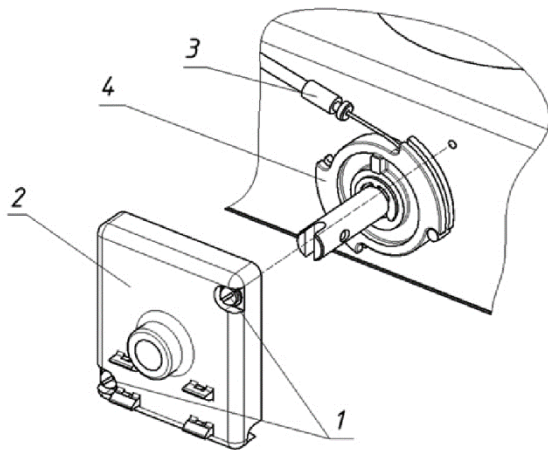

1. Unscrew two captive screws 1;
2. Take off the plastic cover 2;
3. Install release cable 3 in cam 4;
4. Put the plastic cover back and tighten two screws 1.

Figure 52

Connection of release cable to the ISM interlocking shaft

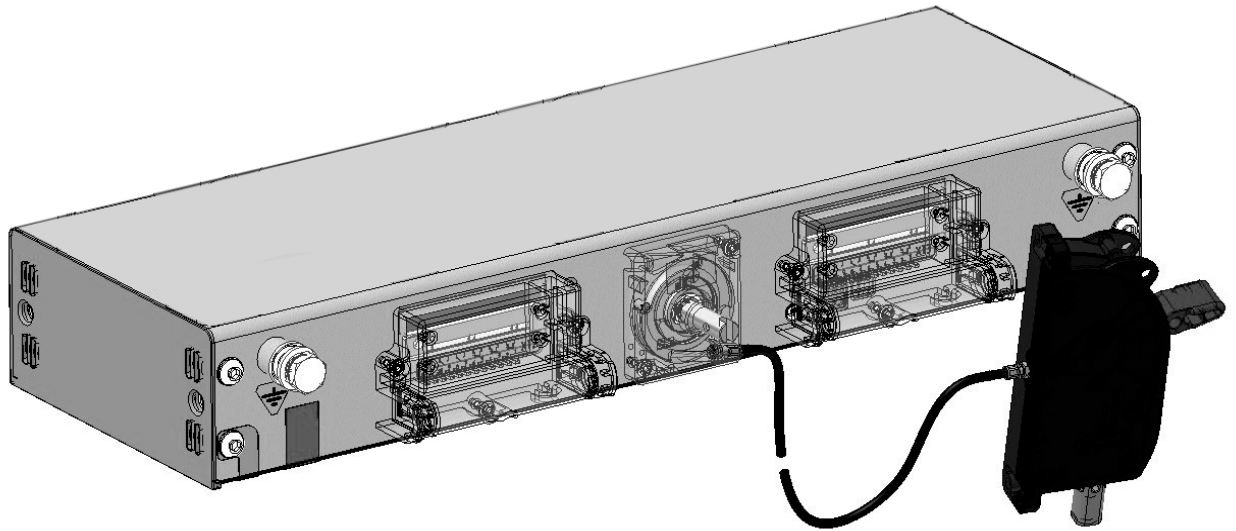
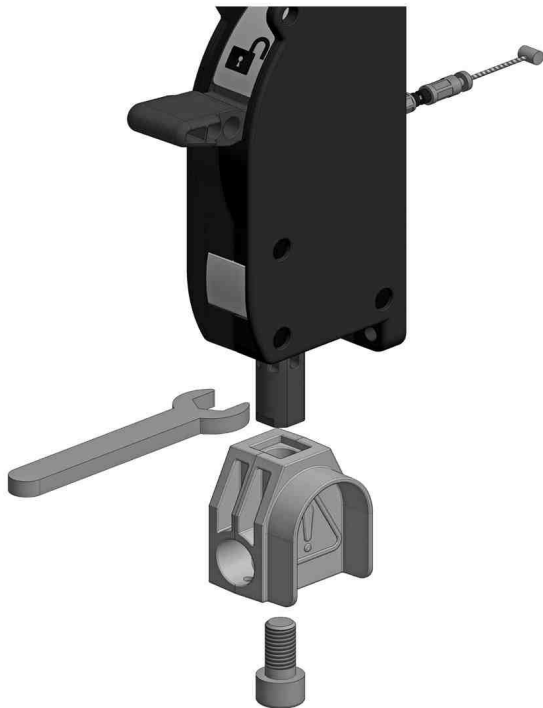

Figure 53
Connection of CBkit_Interlock_3 to the ISM interlocking shaft

Installation and adjustment of CBkit_Interlock_3 in the Switchgear is shown in the Figure 54– Figure 60.



Install CBdet_Stopper_2 on the CBunit_Interlock_1(1) with help of StandDet_Screw_DIN912(M10_20_Fe88-Zn) from the delivery kit of CBkit_Interlock_3. The orientation of CBdet_Stopper_2 depends on the way of next installation of CBunit_Interlock_1(1).

During fixation of StandDet_Screw_DIN912(M10_20_Fe88-Zn) the rod of CBunit_Interlock_1(1) shall not be loaded by torque, the wrench shall be used for rod unloading.

Figure 54
Installation of CBdet_Stopper_2 on the CBunit_Interlock_1(1)

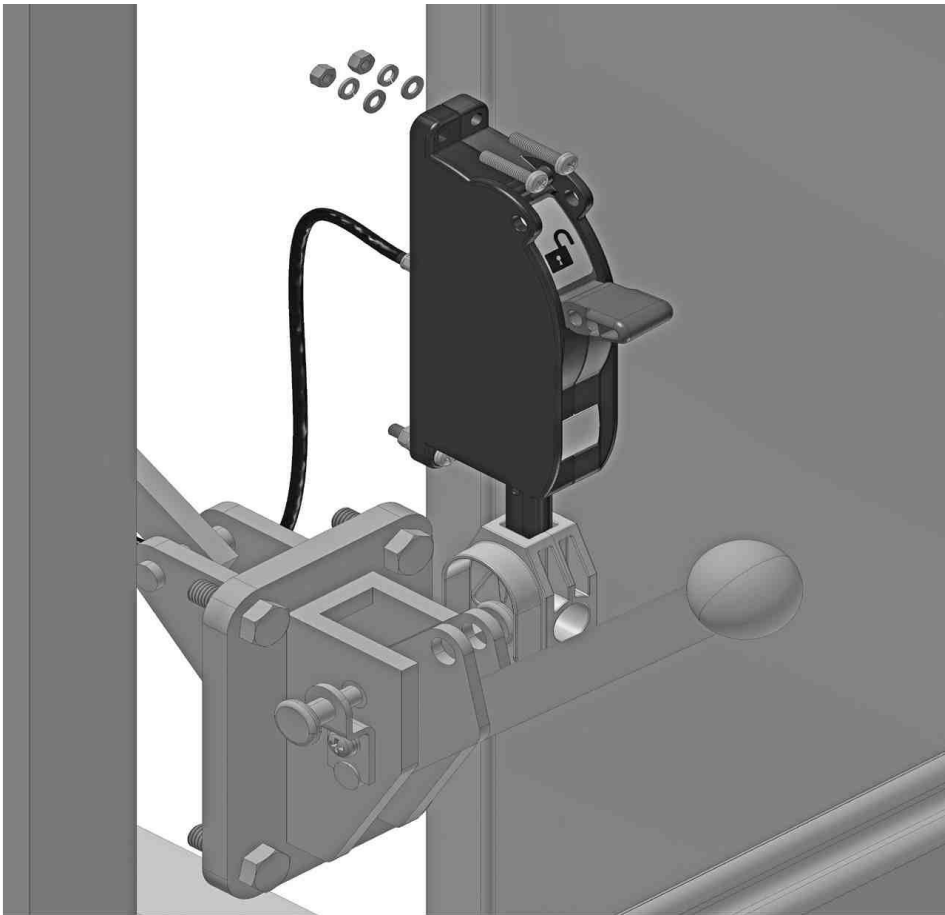
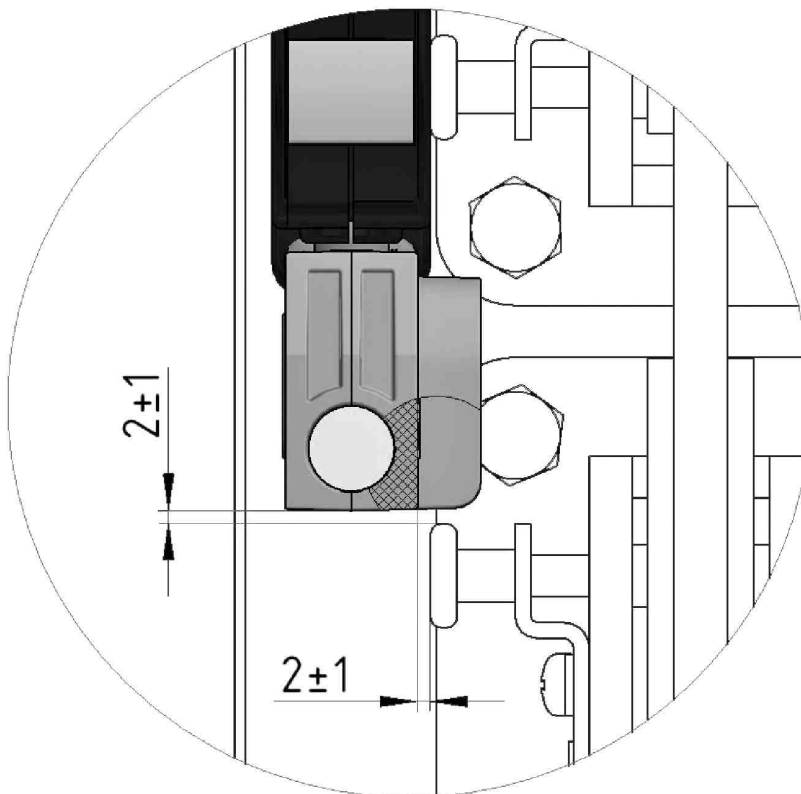

Figure 55
Installation of CBunit_Interlock_1(1) for variant with one or with two straddling disconnectors



The state of the disconnector - unlocked,
 the state of the ISM - locked.

Figure 56
Adjustment of CBunit_Interlock_1(1) installation for variant with one or with two straddling disconnectors

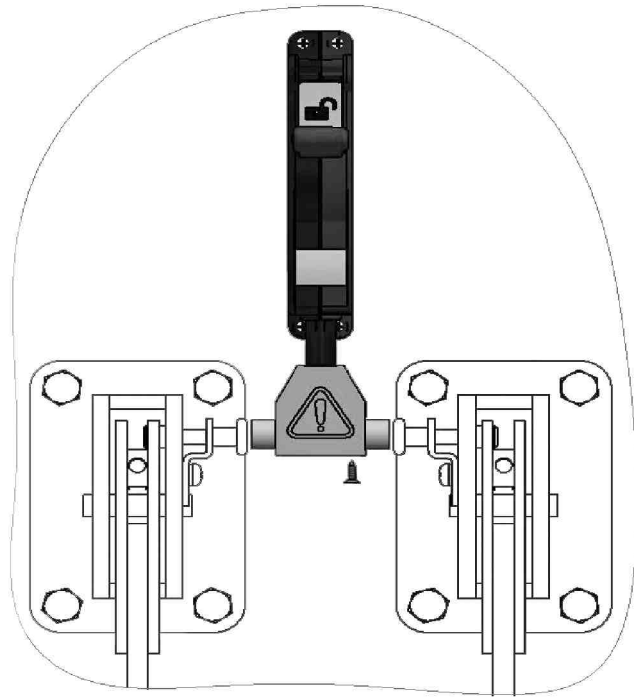
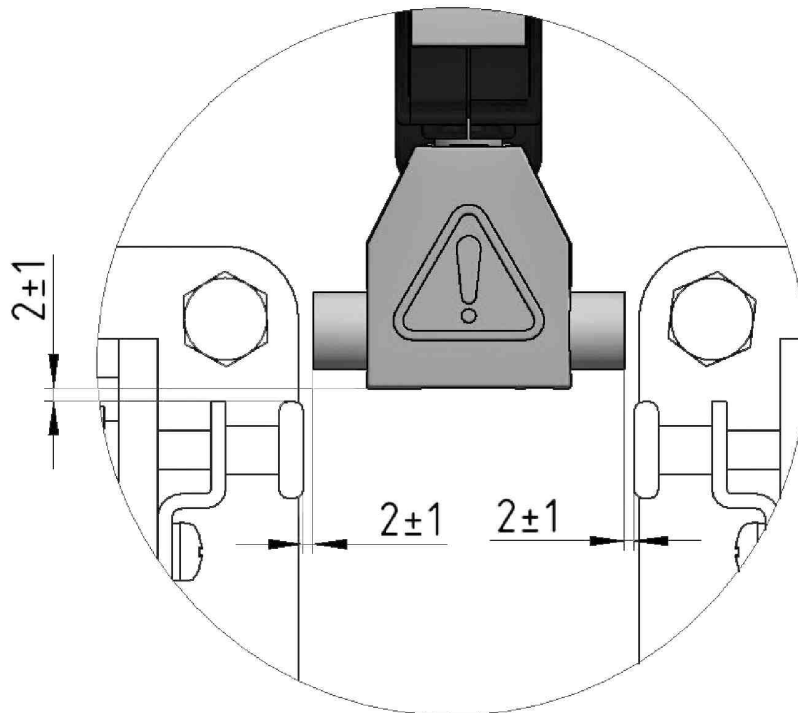

Figure 57
Installation of CBUnit_Interlock_1(1) for variant with two disconnectors



The state of the disconnector - unlocked, the state of the ISM - locked.

Figure 58
Adjustment of CBUnit_Interlock_1(1) installation for variant with two disconnectors



Figure 59

Fixation of CBunit_Interlock_1(1)

CBunit_Interlock_1(1) shall be fixed with help of:

- StandDet_Screw_DIN7985-Ph(M5_25_Fe48-Zn);
- StandDet_Washer_DIN125-1A(5.3_Fe-Zn);
- StandDet_Washer_DIN127-A(5_Fe-Zn);
- StandDet_Nut_DIN555(M5_Fe-Zn)

from the delivery kit of CBkit_Interlock_3. Alternatively StandDet_Screw_DIN7504-K(4.8_19_Fe-Zn) from the delivery kit of CBkit_Interlock_3 can be used.

The flexible release cable shall be fixed in the Switchgear with help of StandDet_CableTie_LS(4.6_150_40) from the delivery kit of CBkit_Interlock_3. If necessary, the stroke of flexible release cable can be adjusted as shown in the Figure 60.

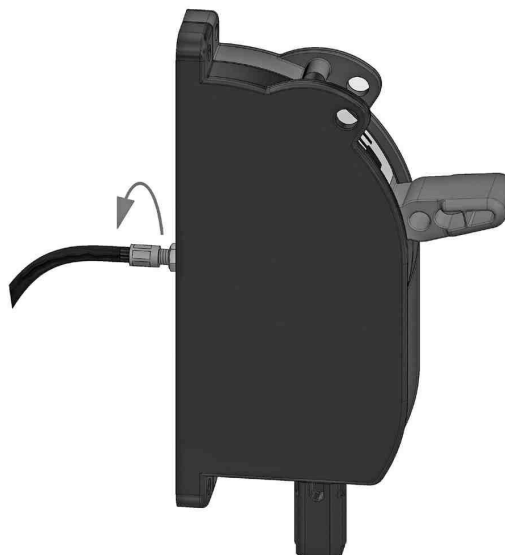

Figure 60

Adjustment of stroke of flexible release cable

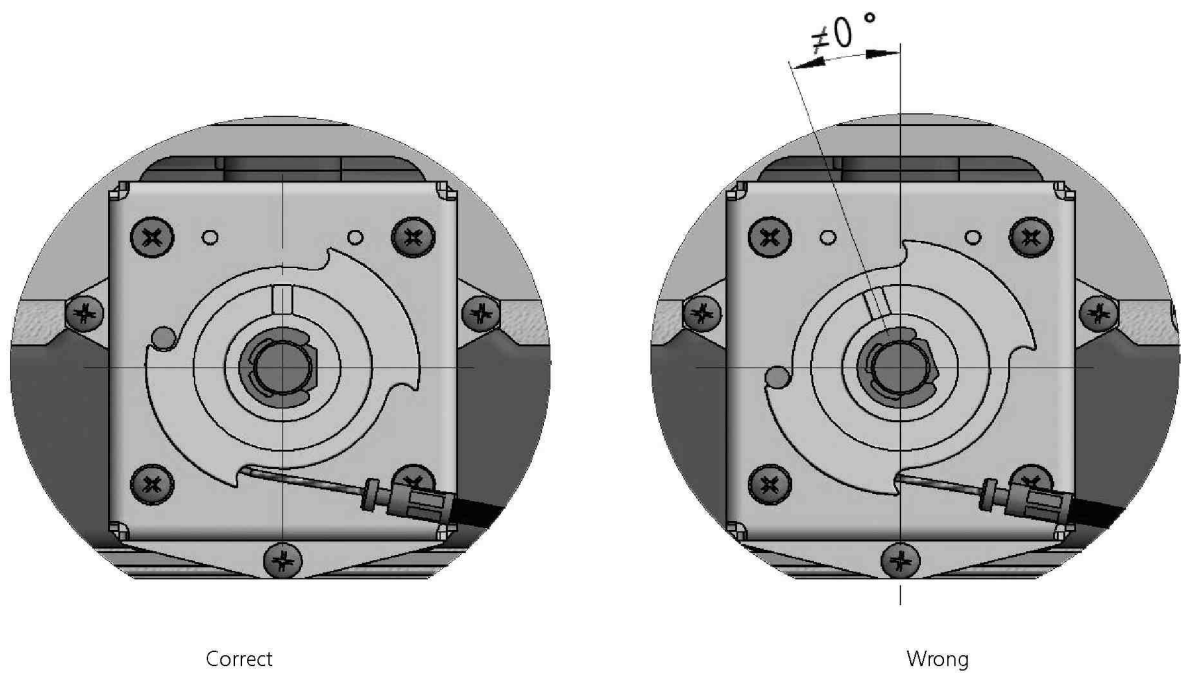

Figure 61
Position of interlocking shaft of the ISM with connected CBkit_Interlock_3

Connection of CBkit_Interlock_4 to ISM15_MD_1, ISM15_MD_3 interlocking shaft

CBkit_Interlock_4 can be used with the ISM15_MD_1, ISM15_MD_3 as an accessory for manual trip / lockout of the ISM by rotary switch.

The connection of the CBkit_Interlock_4 to the ISM15_MD_1, ISM15_MD_3 interlocking shaft is shown in the Figure 52 and Figure 62. The ISM shall be in unlatched position.

Notes:

- the bending radius of the flexible release cable shall be not less than 100 mm;
- it is recommended to install ISM in the Switchgear and connect its auxiliary circuits prior interlock connection to simplify the connection and adjustment process;
- if the flexible release cable passes through the Switchgear segregations according to the design solution it is recommended to pass it through these segregations prior interlock connection.

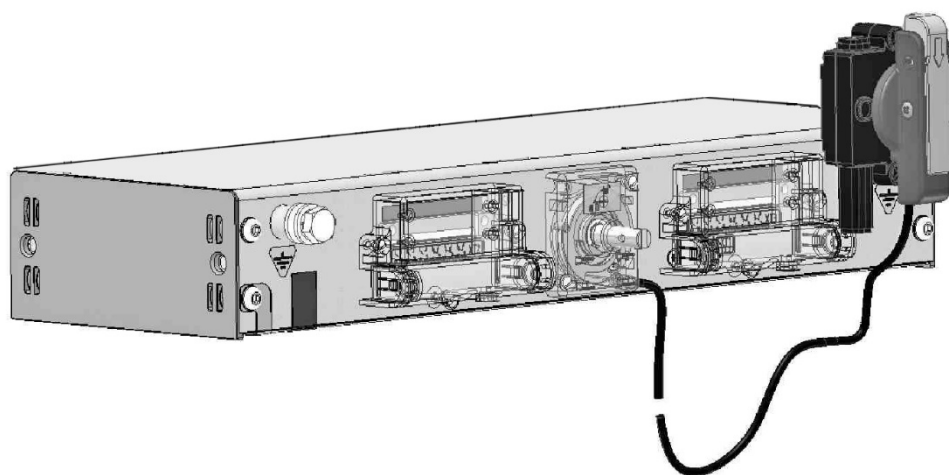

Figure 62
Connection of CBkit_Interlock_4 to the ISM interlocking shaft

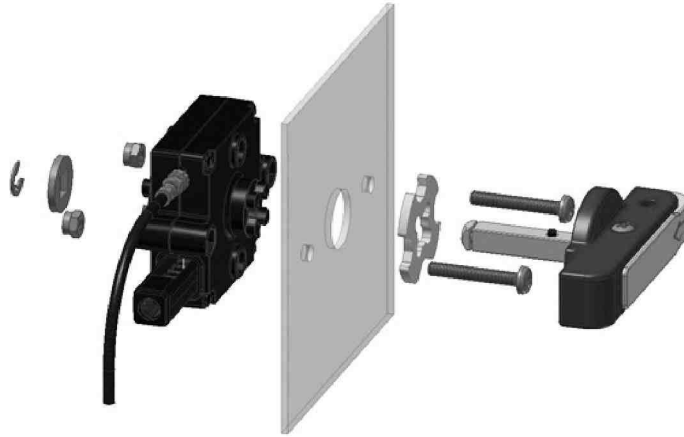

Figure 63

CBkit_Interlock_4 mounting on the Switchgear door

Adjustment of CBkit_Interlock_3 in the Switchgear is shown in the Figure 60.

Connection of CBkit_Interlock_5 to ISM15_MD_1, MD_3 interlocking shaft

CBkit_Interlock_5 can be used with the ISM15_MD_1, ISM15_MD_3 as an accessory for manual trip of the ISM as a manual trip button.

The connection of the CBkit_Interlock_5 to the ISM15_MD_1, ISM15_MD_3 interlocking shaft is shown in the Figure 60 and Figure 64. The ISM shall be in unlatched position.

Notes:

- the bending radius of the flexible release cable shall be not less than 100 mm;
- it is recommended to install ISM in the Switchgear and connect its auxiliary circuits prior interlock connection to simplify the connection and adjustment process;
- if the flexible release cable passes through the Switchgear segregations according to the design solution it is recommended to pass it through these segregations prior interlock connection.

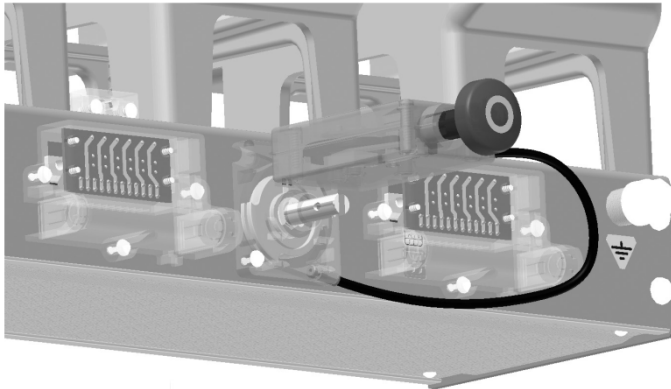

Figure 64

Unscrew the self-tapping screws of the transparent cover and remove it.

4.1.5 Installation of ISM15_MD_1, ISM15_MD_3 main contacts position indicator

The installation of the main contacts position indicator is shown below. (Figure 65 - Figure 67). The ISM shall be in the Closed position.

Notes:

- the bending radius of the flexible indication cable shall be not less than 40 mm.

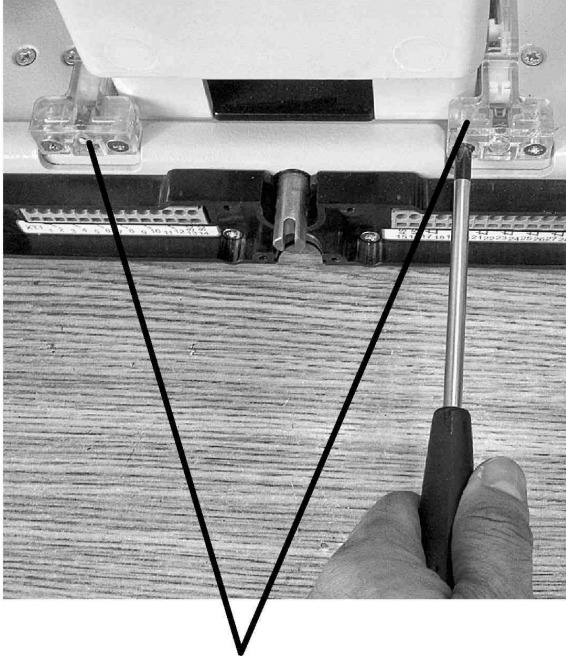

Figure 65
Connection of CBkit_PosInd_1 to the ISM

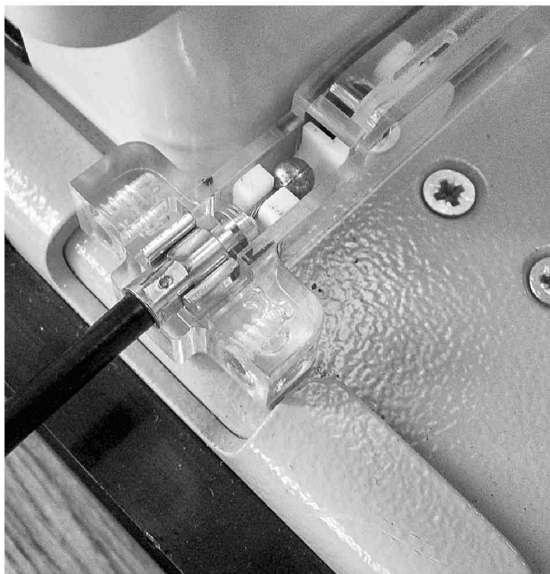
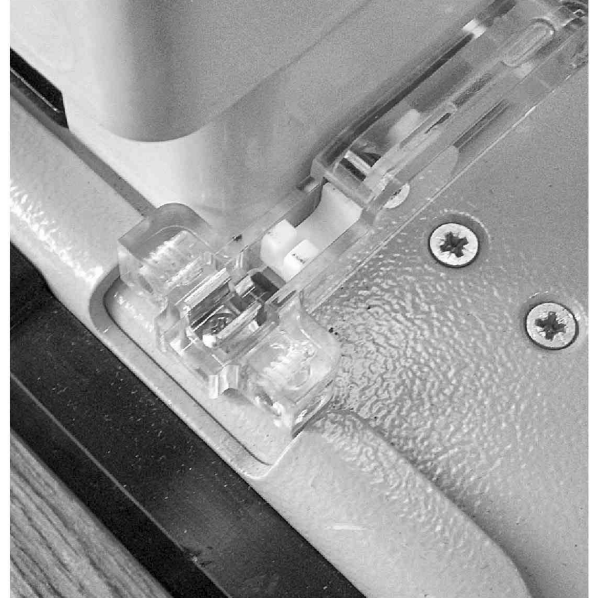

Figure 66
Drop the boss of the wire horizontally into the slot. Insert the end of the sheath into the V-shape spring contact.



Figure 67
Return the cover and fasten it to the ISM.



Figure 68
Adjust the indicator for both closed and opened states of the switching module.



Figure 69
Position indicator shows that main contacts are open



Figure 70
Position indicator shows that main contacts are closed

Installation of insulation kit CBkit_Ins_4

CBkit_Ins_4 will be provided with the ISM15_MD_1 and ISM15_MD_3 as an accessory to comply with the rated impulse withstand voltage of 95 kV. The installation of the CBkit_Ins_4 is shown in the Figure 71 and Figure 72.



a) put insulator CBdet_RubberIns_2 on the busbar

b) connect busbar to the ISM terminal

c) screw the bolt M12 with torque 50 ± 2 H*m



d) cover the ISM terminal tightly by put insulator CBdet_RubberIns_2



e) insulation of double bars 40x10 mm connection is the same, insulator CBdet_RubberIns_2 shall be cut to fit with double bars

Figure 71

Installation of CBkit_Ins_4(1) in case of busbars 40x10 mm usage



- a) cover the bar by shrinkable tube in case it is required b) put insulator CBdet_RubberIns_3 on the busbar



- c) screw the bolt M12 with torque 50 ± 2 H*m and cover the ISM terminal tightly by put insulator CBdet_RubberIns_3

Figure 72

Installation of CBkit_Ins_4(2) in case of busbars 80x10 mm usage

4.1.6 Protective ground

For personnel protection the metal housing of the ISM must be connected according to the applicable regulations, such as IEEE C37.09, NFPA 70 via the marked earth screw of the ISM to the ground arrangement of the particular panel. The ground connection can be carried out with a cable or a copper bar. The area around the ground screw shall be cleaned before providing the ground connection. After the occurrence of a short circuit, the proper condition of the protective ground must be checked.

Table 8 - Reference values for cross sections of earth connections (copper)

Fault current (1 s)	Maximum temperature	Cross section of earth connection
16 kA	300 °C	55-95 mm ² (2/0 AWG or larger)
20 kA	300 °C	70-120 mm ² (3/0 AWG or larger)
25 kA	300 °C	95-140 mm ² (4/0 AWG or larger)
31.5 kA	300 °C	120-190 mm ² (240kcmil or larger)

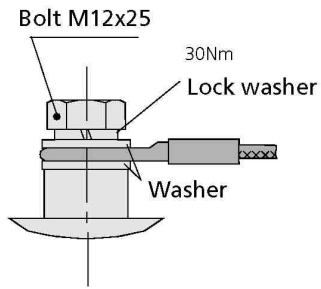

Figure 73
ISM protective ground connection

The method of ISM15_MD_1, grounding is shown in the Figure 74.

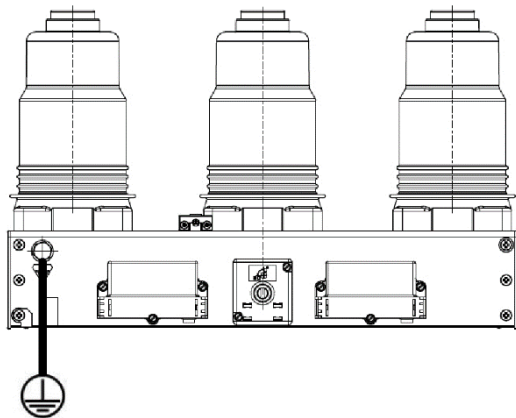

Figure 74
ISM15_MD_1 grounding

An example of one side copper bar ground is represented in Figure 72.

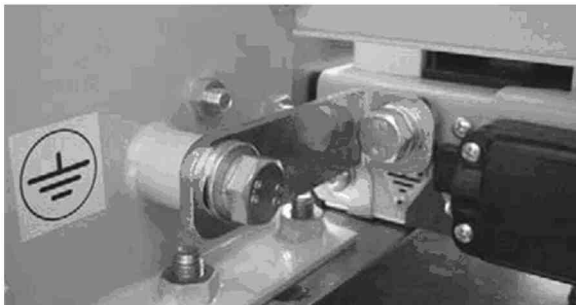

Figure 75
Example of grounding the ISM by copper busbar

4.2 Secondary part

4.2.1 Three-phase ISM secondary connections

ISM15_MD_1 have secondary connectors as shown below.



a) ISM actuator coil terminal

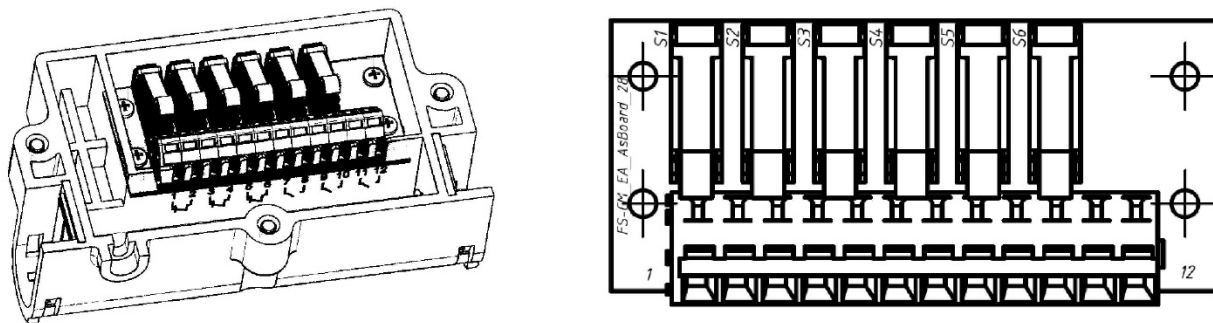

b) Auxiliary switches board EA_Asboard_28 (XT2, XT3)

Figure 76

Terminal arrangement of the ISM15_MD_1

Note: The ISM15_MD_1 is supplied with auxiliary switches boards.

Table 9 - ISM15_MD_1 terminal arrangement

XT1		XT2, XT3 (Auxiliary switches board EA_Asboard_28)	
Terminal No.	Connection	Terminal No.	Connection
1	Actuator coil (SC1)	1	NC auxiliary switch S 1(1)
2	Actuator coil (SC2)	2	NC auxiliary switch S 1(1)
		3	NC auxiliary switch S 2(1)
		4	NC auxiliary switch S 2(1)
		5	NC auxiliary switch S 3(1)
		6	NC auxiliary switch S 3(1)
		7	NO auxiliary switch S 4(1)
		8	NO auxiliary switch S 4(1)
		9	NO auxiliary switch S 5(1)
		10	NO auxiliary switch S 5(1)
		11	NO auxiliary switch S 6(1)
		12	NO auxiliary switch S 6(1)

4.2.2 Single-phase ISM secondary connections

Single-phase ISM15_MD_3 has secondary connectors as shown below.

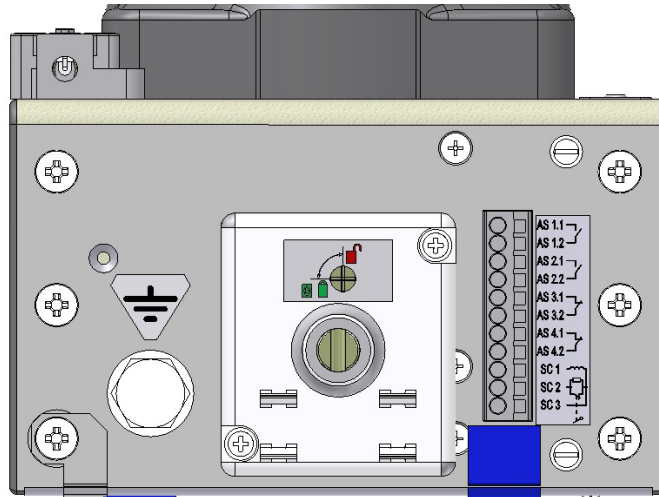

Figure 77

Terminal arrangement of the single-phase ISM15_MD 3

Table - Single-phase ISM15_MD_3 terminal arrangement

XT1	
Terminal No.	Connection
1	Auxiliary switch AS1 (AS1.1)
2	Auxiliary switch AS1 (AS1.2)
3	Auxiliary switch AS2 (AS2.1)
4	Auxiliary switch AS2 (AS2.2)
5	Auxiliary switch AS3 (AS3.1)
6	Auxiliary switch AS3 (AS3.2)
7	Auxiliary switch AS4 (AS4.1)
8	Auxiliary switch AS4 (AS4.2)
9	Actuator coil (SC1)
10	Actuator coil (SC2) with internal interlock
11	Actuator coil (SC3) without interlock

Note: Actuator coil input CS3 is intended for case when internal interlock is not required. For instance, when three single-phase ISM15_MD_3 are connected in parallel to one control module. In such case the interlock of one of these ISMs can be used. Please contact the nearest Tavrida Electric sales representative for cases when three single-phase ISM15_MD_3 are connected in parallel to one control module for more information.

4.2.3 CM secondary connections

CM_16_1 has secondary connectors as shown below.

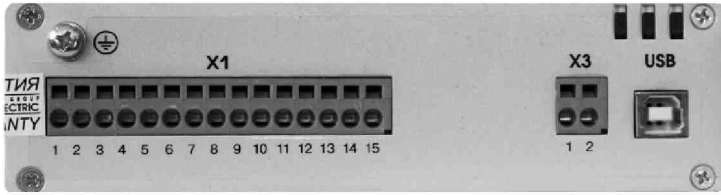

Figure 78

Terminal arrangement of the CM_16_1

Table 10 - CM_16_1 terminal arrangement

X1		X3	
Terminal No.	Connection	Terminal No.	Connection
1	Power supply input (+)	1	Actuator coil output
2	Power supply input (-)	2	Actuator coil output
3	Relay output 1 NO		
4	Relay output 1 Com		
5	Relay output 1 NC		
6	Relay output 2 NO		
7	Relay output 2 Com		
8	Relay output 2 NC		
9	Relay output 3 NO		
10	Relay output 3 Com		
11	Relay output 3 NC		
12	Close input		
13	Close input		
14	Trip input		
15	Trip input		

CM relay functionality:

- Relay 1 - “ISM main contact position” relay;
- Relay 2 - “Ready” relay;
- Relay 3 - “Malfunction of Loss of auxiliary supply” relay.

Normal contact position (when NO contacts are open, NC contacts are closed) are following:

- For relay “Ready” – when breaker is not ready;
- For relay “ISM main contacts position” – when breaker is open;
- For relay “Malfunction or Loss of auxiliary supply” – when there is no malfunction detected.

Relay “ISM main contact position“ keeps its state after CM power supply disconnection.

USB port of CM is not used under service conditions (only for CM programming during production).

CM_16_2 has secondary connectors as shown below.

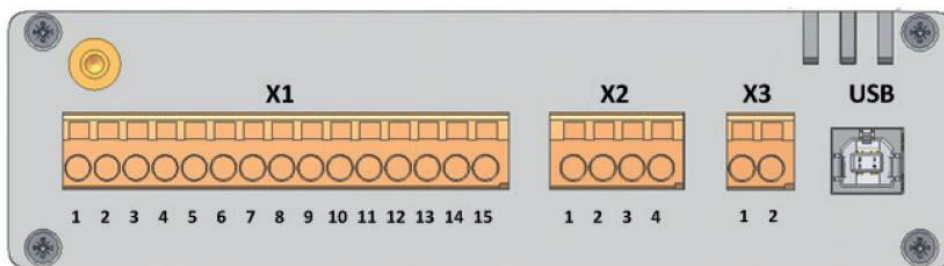

Figure 79
Terminal arrangement of the CM_16_2

Table 11 - CM_16_2 terminal arrangement

X1				X3	
Terminal No.	Connection	Terminal No.	Connection	Terminal No.	Connection
1	Power supply input (+)	1	CT input 1	1	Actuator coil output
2	Power supply input (-)	2	CT input 1	2	Actuator coil output
3	Relay output 1 NO	3	CT input 2		
4	Relay output 1 Com	4	CT input 2		
5	Relay output 1 NC				
6	Relay output 2 NO				
7	Relay output 2 Com				
8	Relay output 2 NC				
9	Relay output 3 NO				
10	Relay output 3 Com				
11	Relay output 3 NC				
12	Close input				
13	Close input				
14	Trip input				
15	Trip input				

4.2.4 Installation of the CM

The installation of the CM_16_1 is carried out according to the panel design either on the draw out unit or in the low voltage compartment of the switchboard. It must be separated from the high voltage compartment.

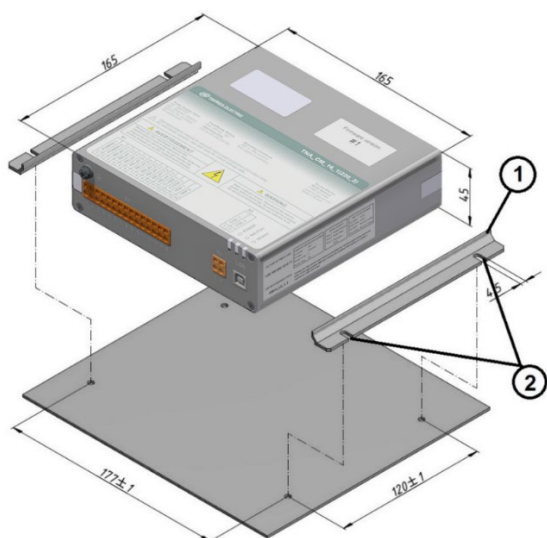

1. CM holders
2. Slots for CM mounting (by M4 screws)

Figure 80
Provisions for CM_16_1 installation

The CM can operate in any mounting position. Care must be taken for access and visibility of the terminals, LEDs.

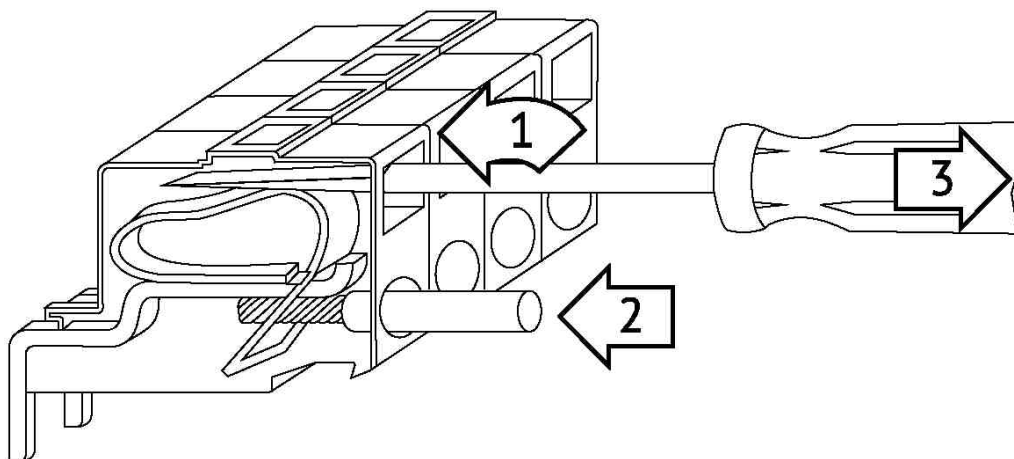

Figure 81
Installation to CM terminals

Wires are connected to the CM terminals by using a screwdriver (Figure 19). The terminals can accept solid and stranded wire within the range 0.5-2.5 mm (14 - 18 AWG). Use copper conductors only. All wires insulation must be rated 600V or better. The insulation stripping length shall be 6-10 mm. Insulated auxiliary circuits shall provide 2 kV power frequency dielectric strength.

4.2.5 Installation of secondary cables between ISM and CM

Before connecting the CM_16_1 to the ISM compliance between ISM type (shown on ISM serial number plate – Figure 2) and CM (applicability of CM for particular type of ISM are shown on CM designation label – Figure 4 and CM packing label - Figure 18) shall be confirmed.

Warning! If the CM label does not show the correct ISM type do not use the CM. It can lead to damage of the ISM. Contact your nearest Tavrida Electric partner for replacement.

Secondary cables between ISM and CM shall be installed according to the following instructions (Figure 82 -

Figure 83). To achieve best possible protection against electromagnetic influences. The earthing point 3  shall be as close as possible to the CM. Unshielded parts of wires shall be not longer than 10 cm. Connections between the end of cable shields and ISM earthing points shall be not longer than 5 cm. Cable insulation must be rated 300V or better. Only ring type cable lug or similar should be used for CM16 earthing point connection.

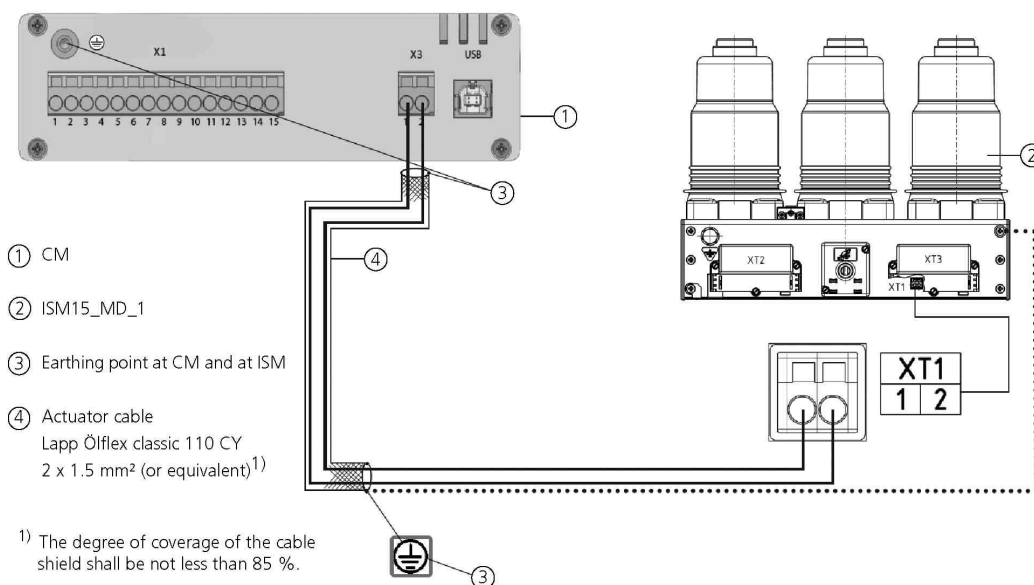

Figure 82
Secondary cables between ISM15_MD_1 and CM_16_1

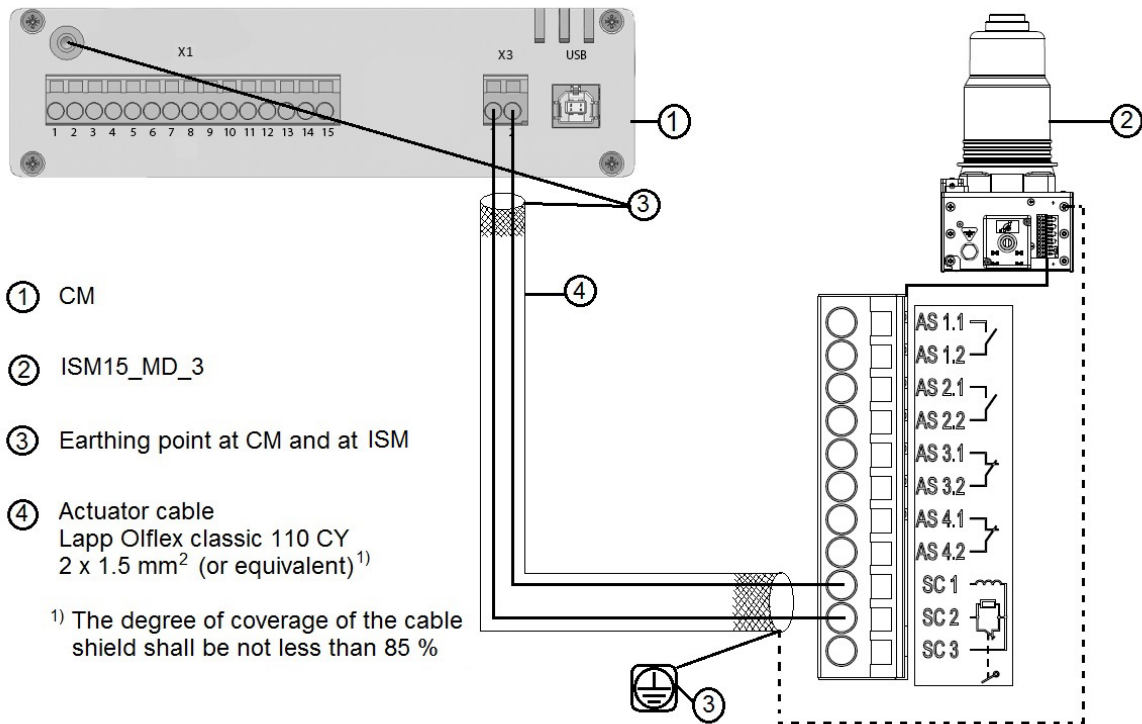

Figure 83
Secondary cables between ISM15_MD_3 and CM_16_1

Even after the CM is disconnected from all the power supplies there still may be hazardous voltage on the CM connectors. Achievement of safe voltage level is indicated by the extinction of all LEDs on the CM front panel. This may take up to 15 minutes after the CM is deenergized.



Figure 84
Sample of earthed cable shielding on ISM side

4.2.6 Auxiliary supply

Connection of CM_16_1 to power supply is shown below.

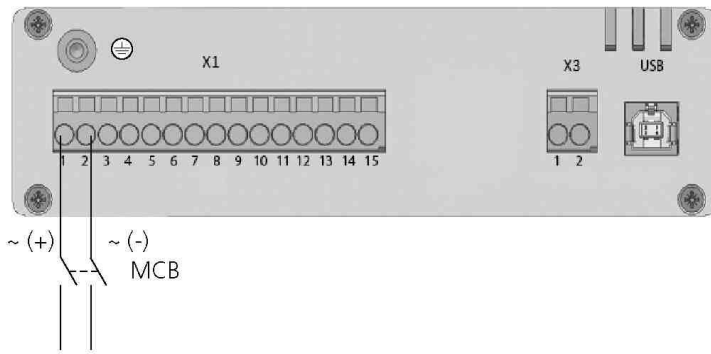

Power supply inputs

Figure 85

CM_16 power supply connection

Type of ISM shall be selected according to CM data given in Table 1.

If the CM is connected to DC voltage, pay special attention to the correct polarity for CM_16_1(60_1).

If Manual generators CBunit_ManGen are used for charging the CM, DC voltage outputs shall be connected to power supply inputs of CM.

Arrangement of output wires of Manual generators CBunit_ManGen_1 and CBunit_ManGen_2:

- red color wire - positive polarity output wire;
- black color wire - negative polarity output wire;
- yellow-green color wire - manual generator earthing wire.

4.2.7 CM indication

The CM has the following LED indication functionality:

CM "Power" indication;

CM "Ready" state indication;

CM "Malfunction" state indication.

The placement of LED indicators are shown in figures below. The LED indicators on CM_16_1 are visible from two directions.

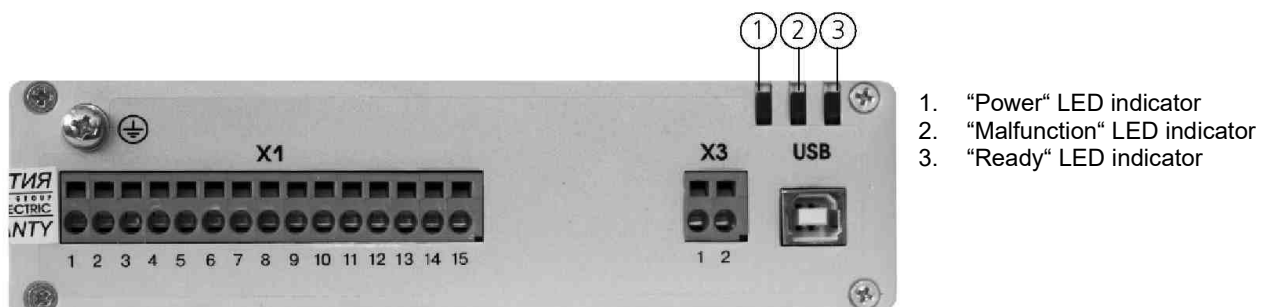

Figure 86

CM_16_1 LED indicators

The self-diagnostic system inside the CM detects possible malfunctions and reports them via the Malfunction LED blink signals and Malfunction or Loss of auxiliary supply Relay state. The explanation of the LED blink codes is given in Table 11.

Table 12 – CM_16_1 self-diagnostic indication

CM state	Indication		
	LED Power	LED Ready	LED Malfunction
Power supply voltage is absent more than 3 minutes	off	off	off
"Close" operation is preparing	continuous	off	off
CM_16_1 is ready and operable	continuous	continuous	off
Power supply voltage is absent for more than 1.5 seconds	off	continuous	1 blink
Excessive trip or close time	continuous	off	2 blinks
Actuator coil isolated	continuous	off	3 blinks
Short circuit of Actuator coil	continuous	off	4 blinks
Manual Trip and Lock	continuous	off	5 blinks
Out of temperature range	continuous	off	6 blinks
ISM state is open without command from the CM_16_1	continuous	off	7 blinks
Internal fault of the CM_16_1	continuous	off	continuous

Notes.

1. Number of blinks in series followed by 1.5 s intervals, continuous light or off state are shown for LED indicators.
2. Period of checking Actuator Coil state (short circuit / isolated) – 10 s.

Priority of the fault indication starting from the lowest one:

1. CM_16_1 is out of temperature range;
2. ISM state is open without command from the CM_16_1;
3. Excessive trip or close time;
4. Manual Trip and Lock;
5. Actuator coil isolated;
6. Short circuit of Actuator coil;
7. Power supply voltage is absent more than 1.5 seconds.

4.2.8 CM relay contacts operation

Relay contacts of CM_16_1 change their state as described below.

Table 13 - CM relay “Ready” contacts operation

CM state	Relay “Ready” contacts state	
	NC (terminals 7-8 by default)	NO (terminals 6-7 by default)
CM is ready for close or open operation	Open	Closed
CM is not ready for close or open operation	Closed	Open

Table 14 - CM relay “ISM main contact position” contacts operation

ISM state	Relay “ISM main contact position” contacts state	
	NC (terminals 4-5 by default)	NO (terminals 3-4 by default)
ISM is closed	Open	Closed
ISM is open	Closed	Open

CM performs the checkup of ISM main contacts position and updates the “ISM main contacts position” relay status in the following cases:

- In case Close command was applied from the CM. In this case the update is performed not later than in 150 ms after ISM main contacts closing;
- In case Trip command was applied from the CM. In this case the update is performed not later than in 70 ms after ISM main contacts opening;
- Periodically every 10 s in case no Close or Open command was applied from the CM.

In case application project requires to define main contacts position faster than the timing mentioned above it is recommended to use auxiliary switches installed at the ISM. Position indication of ISM provided by CM can be incorrect, in case CM is not operable due to absence of auxiliary supply.

Table 15 - CM relay “Malfunction or Loss of auxiliary supply” contacts operation

CM state	Relay “Malfunction or Loss of auxiliary supply” contacts state	
	NC	NO
Power supply voltage is absent for more than 1.5 seconds (1 blink of LED Malfunction)	Open	Closed
Excessive trip or close time (2 blinks of LED Malfunction)	Open	Closed
Actuator coil isolated (3 blinks of LED Malfunction)	Open	Closed
Short circuit of Actuator coil (4 blinks of LED Malfunction)	Open	Closed
Manual Trip and Lock (5 blinks of LED Malfunction)	Closed	Open
Out of temperature range (6 blinks of LED Malfunction)	Closed	Open
ISM state is open without command from the CM (7 blinks of LED Malfunction)	Open	Closed
Internal fault of CM (continuous light of LED Malfunction)	Open	Closed

4.2.9 CM_16_1 Series Factory Programmable Options

The CM_16 series is a flexible control module option with an array of factory programmable settings for optimizing control of the ISM breakers. When ordering a CM_16, the model code along with the pre-programmed settings code should be submitted to Tavrida. Use the Table 15 for configuration of a settings code based on the following options guide:

Breaker Type

To optimize the closing and trip pulses to the ISM actuators, this option sets various features of the CM_16 output power algorithm. Each model type of the ISM_LD series breakers can be selected. Note that connection to an ISM other than the one selected will produce a malfunction signal.

Undervoltage Functions

The CM_16 series has an option for automatic trip of the ISM on loss of auxiliary supply. The CM_16 will issue a trip command when the auxiliary supply drops below its minimum threshold (6VDC for the CM_16_1(60_2) and 60VAC / VDC for the CM_16_1(220_2) or CM_16_2(220)).

When set to „ON“, the undervoltage delay parameter becomes active. This can be set from 0 to 60 seconds delay before the CM issues a trip command after loss of auxiliary power.

Similarly, the undervoltage reclosing function becomes active. If set to „2“, the breaker will automatically close when auxiliary power is restored with a delay time as set by the undervoltage reclosing delay parameter.

Digital Outputs

The CM_16 series has x3 output relays for external signalling such as lamps or relay alarm inputs. Each output has five settings options. The output can be disabled; signal close / open position of the breaker primary contacts; signal a loss of auxiliary supply; signal ready for operation; or signal a malfunction.

Trip / Close Delays

The ISM breaker series have high speed actuators for trip and close operations. The CM_16 by default is set for a 12ms trip and close delay time for normal breaker operations. For arc flash mitigation, fast transfer, or other unique applications, this delay time can be adjusted for trip and close independently from 4ms to 40ms in 1ms increments. Note that for delay times less than 12ms the fault interrupting rating of the ISM may need to be reduced; consult Tavrida Applications Engineering for information.

Trip / Close Inputs

The CM_16 series use dry contact trip and close inputs, using any normally open contact by default as the trigger. For some applications such as mining, a normally closed loop is required for the trip circuit whereby any break in the trip connection will cause the breaker to open. For this purpose the CM_16 close and trip inputs can be set independently for either NO or NC triggers.

Table 16 - Pre-Programmed Settings Code Designations Table

Parameter	Settings Code	Options
BREAKER TYPE	10	ISM15_MD_1
	12	ISM15_MD_3

UNDERVOLTAGE	0	Undervoltage OFF
	1	Undervoltage ON
UV DELAY	0 - 60	Undervoltage Delay (0 - 60s)

RECLOSING	1	Reclosing - 0 Trips to Lockout
	2	Reclosing - 1 Trip to Lockout
RECLOSING DELAY	1	Reclosing Delay (15 - 60s)

DIGITAL OUTPUT 1	1	Disable
	2	Closed
	3	LS1 Open
	4	Driver Ready
	5	Malfunction

	6	Power Supply Loss
	7	Malfunction + Power Supply Loss

DIGITAL OUTPUT 2	1	Disable
	2	Closed
	3	LS1 Open
	4	Driver Ready
	5	Malfunction
	6	Power Supply Loss
	7	Malfunction + Power Supply Loss

DIGITAL OUTPUT 3	1	Disable
	2	Closed
	3	LS1 Open
	4	Driver Ready
	5	Malfunction
	6	Power Supply Loss
	7	Malfunction + Power Supply Loss

TRIP DELAY	4 to 40	Trip Delay (4 - 40ms)
CLOSE DELAY	4 to 40	Close Delay (4 - 40ms)

TRIP INPUT	1	By closing the contact
	2	By opening the contact
CLOSE INPUT	1	By closing the contact
	2	By opening the contact

Example

For a control module programmed with breaker type ISM15_MD_1, UV on, UV delay of zero seconds, 1 trip to lockout with 60 second reclosing delay, DO1 = Close / Open Position, DO2 = Driver Ready, DO3 = Malfunction, trip delay of 12ms, close delay of 12ms, trip input = By opening the contact, close input = By opening the contact:

Settings code = 10-10-260-245-1212-22

4.2.10 CM_16_1 Series Operations counter reading.

The CM_16 series control modules have breakers operations counter function built in. The counter is available for reading with Tavrída software.

Reset the initial amount of operations stored in the control module associated with connected circuit breaker prior to put it into service.

Use Tavrída software to access the value of counted operations when you need.

To get access to operations counter install the CM16 configuration tool. The operations counter can be found under the settings tab.

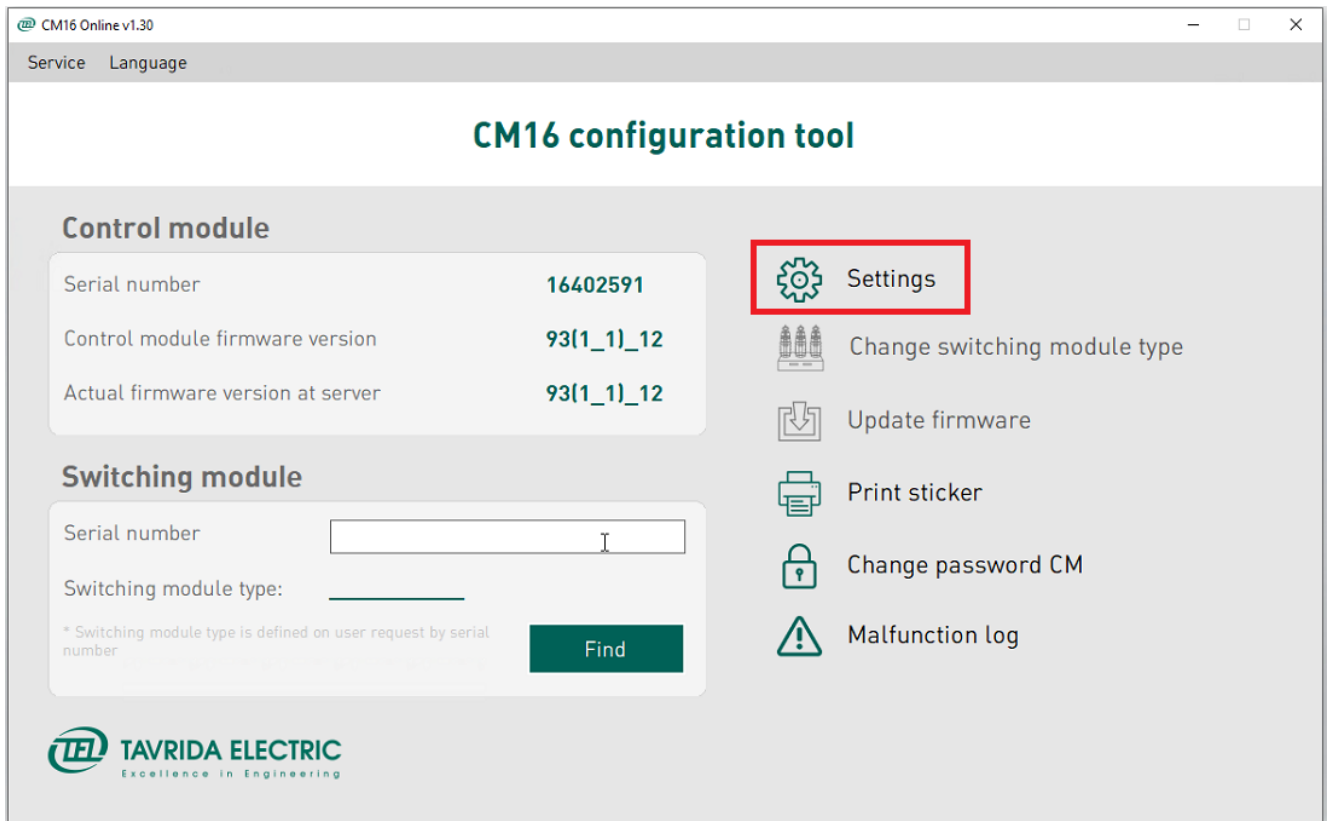

Figure 87
CM16 configuration tool

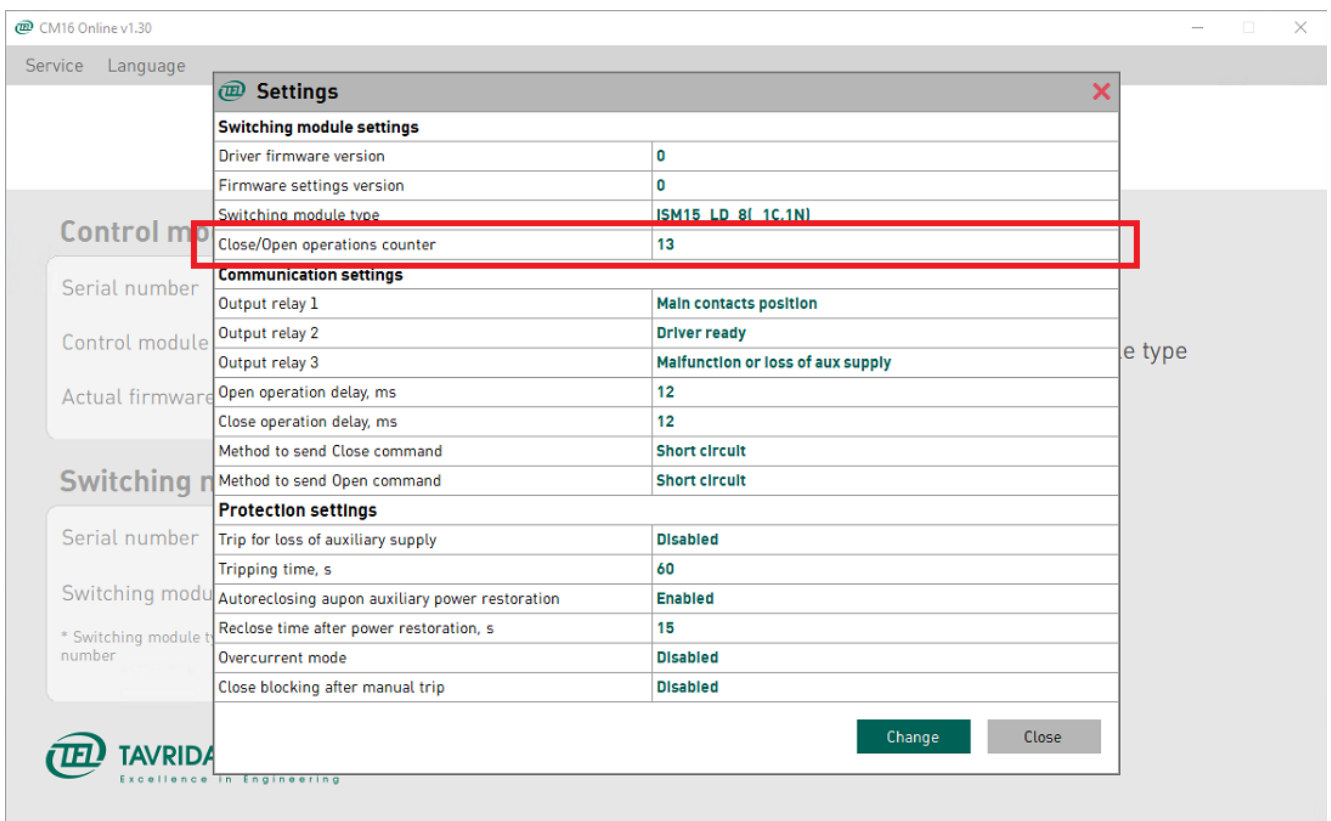

Figure 88
Operations counter in CM16 configuration tool

5 Commissioning

The list of commissioning operations and checks is shown in Table 16 below. Initial state of VCB components before checks: ISM - open, CM - deenergized. Main circuits of ISM shall be disconnected/isolated from the main circuits of substation to avoid high voltage being applied to the ISM before the commissioning procedure completion. Commissioning and maintenance is only permitted for qualified and trained personnel.

Table 17 - List of commissioning operations and check-ups

Operation description	Required tool	Approximate timing
	Tests at the end of installation	
Check for damage, remove any dirt, contamination or moisture	Visual check, no tool is required	2 minutes
Unsupported busbar length shall be according to Table 5 for ISM15_MD	Ruler, tape measure or calliper - depends on distance value and place of measurement execution	2 minutes
Fixing points shall be according to Figure 37	Visual check, no tool is required	1 minute
Bolts and torques shall be according to Figure 37	Torque wrench according to torque value	2 minutes
Clearances shall be according to subchapter 4.1.3	Ruler, tape measure or calliper - depends on distance value and place of measurement execution	2 minutes
Protective earthing shall be according to subchapter 4.1.6	Visual check, no tool is required	1 minute
Check that free air circulation at ISM is possible	Visual check, no tool is required	1 minute
Installation of CM shall be according to subchapter 4.2.4	Visual check, no tool is required	1 minute
Availability of the CM auxiliary power supply. It is recommended to use the same auxiliary power supply as for protection and control devices. Type of voltage and voltage level according to selected CM type	Voltmeter with measurement range according to expected power supply voltage value	2 minutes
Polarity of auxiliary power supply and selection of MCB shall be according to subchapter 4.2.6. Check of compliance between ISM type on ISM serial number plate and on CM designation label	DC voltmeter with measurement range according to expected power supply voltage value - for voltage polarity check. Visual check, no tool is required – for MCB check	2 minutes
Connection between CM and ISM shall be according to subchapter 4.2.5	Multimeter - for validation of correct wiring connections (utilizing the continuity function of the meter)	5 minutes
Checking that all secondary connections have been secured adequately	Visual and mechanical check of connections, no tool is required	2 minutes
Checking whether the CM, ISM are connected according to project/ product documentation and according to circuit diagrams in „Appendix 3. Secondary schemes“.	Multimeter - for validation of correct wiring connections (utilizing the continuity function of the meter)	5 minutes
Connect computer to control module USB port to read actual operations counter value. Store the value together with ISM module serial number for future records.	Computer with USB type A port and Tavrada software installed, USB type A to USB type B connection cable.	3 minutes

Operation description	Required tool	Approximate timing
Operation check		
Turn on the CM auxiliary power supply then check the following: <ul style="list-style-type: none"> - The "Power" LED must light up immediately; - The "Ready" LED must light up continuously within 15 s after switching on; - The "Malfunction" LED must not light up; - The "Ready" relay contact must close within 15 s.; - The "Malfunction or Loss of auxiliary supply" relay contact must change its state¹⁾; - The "ISM main contact position" relay contact must not change its state; - ISM main contacts must not change their state (ISM shall remain open). 	Visual check, no tool is required	1 minute
Apply close command to the CM then check the following: <ul style="list-style-type: none"> - The "Power" LED must light continuously; - The "Ready" LED must light continuously; - The "Malfunction" LED must not light up; - The "Ready" relay contact must not change its state; - The "Malfunction or Loss of auxiliary supply" relay contact must not change its state; - The "ISM main contact position" relay contact must change its state; - ISM main contacts must change their state (ISM shall be closed). 	Visual check, no tool is required	1 minute
Apply trip command to the CM then check the following: <ul style="list-style-type: none"> - The "Power" LED must light continuously; - The "Ready" LED must light continuously; - The "Malfunction" LED must not light up; - The "Ready" relay contact must not change its state; - The "Malfunction of Loss of auxiliary supply" relay contact must not change its state; - The "ISM main contact position" relay contact must change its state; - ISM main contacts must change their state (ISM shall be open). 	Visual check, no tool is required	1 minute

1) As earlier, after CM power supply disconnection this relay indicated the CM state: "Power supply voltage is absent for more than 1.5 seconds"

Operation description	Required tool	Approximate timing
Do not remove trip command and apply close command to the CM then check the following: <ul style="list-style-type: none"> - The "Power" LED must light continuously; - The "Ready" LED must light continuously; - The "Malfunction" LED must not light up; - The "Ready" relay contact must not change its state; - The "Malfunction or Loss of auxiliary supply" relay contact must not change its state; - The "ISM main contact position" relay contact must not change its state; - ISM main contacts must not change their state (ISM shall remain open). 	Visual check, no tool is required	1 minute
Remove close and trip commands to the CM then check the following: <ul style="list-style-type: none"> - The "Power" LED must light continuously; - The "Ready" LED must light continuously; - The "Malfunction" LED must not light up; - The "Ready" relay contact must not change its state; - The "Malfunction or Loss of auxiliary supply" relay contact must not change its state; - The "ISM main contact position" relay must not change its state; - ISM main contacts must not change their state (ISM shall remain open). 	Visual check, no tool is required	1 minute
Apply and keep close command and then apply trip command to the CM then check the following: <ul style="list-style-type: none"> - The "Power" LED must light continuously; - The "Ready" LED must go out after the trip of the ISM and then light up continuously within 10 s.; - The "Malfunction" LED must not light up; - The "Ready" relay contact must change its state after the trip of the ISM and then change its state again within 10 s.; - The "Malfunction or Loss of auxiliary supply" relay contact must not change its state; - The "ISM main contact position" relay contact must change its state each time when ISM is closed and open; - ISM main contacts must change their state each time when ISM is closed and open. 	Visual check, no tool is required	1 minute

Operation description	Required tool	Approximate timing
Primary circuits insulation check¹⁾		
Observe safety precautions listed in the danger and warning advisories. Construct proper barriers and warning light systems	Equipment to provide safety in the test area	10 minutes
Ground each pole of ISM that is not under test ²⁾	Wires	2 minutes
Apply slowly rising 100% ³⁾ of test voltage ⁴⁾ (50 or 60 Hz) across each pole for one minute ⁵⁾ . (ISM is open)	Power frequency withstand voltage test set	2 minutes
If the pole sustains the test voltage for that period, its vacuum integrity has been verified ⁶⁾	Power frequency withstand voltage test set	-
Repeat actions above to check each pole of ISM	Power frequency withstand voltage test set, wires	8 minutes
Close the ISM. Ground each pole of ISM that is not under test ²⁾	Wires	1 minute
Apply slowly rising 100% ³⁾ of test voltage ³⁾ (50 or 60 Hz) between a primary conductor of the pole and ground for one minute, repeat test for each pole of ISM	Power frequency withstand voltage test set	12 minutes
If no disruptive discharge occurs, the insulation system is satisfactory	Power frequency withstand voltage test set	-
After the test, ground all main circuit terminals to dissipate any static charge	Wires	2 minutes
Auxiliary circuits insulation check		
Connect all points of the secondary circuits with a shorting wire. ISM coil connection wires must be disconnected from connector X3 of CM before the test	Wires	5 minutes
Connect the shorting wire to the high potential lead of the high voltage tester and ground the circuit breaker housing. Starting with zero volts, gradually increase the test voltage to 1500 V RMS, 50 or 60 Hz. Maintain test voltage for one minute	Power frequency withstand voltage test set	3 minutes
If no disruptive discharge occurs, the secondary circuits insulation level is satisfactory	Power frequency withstand voltage test set	-
Disconnect the shorting wire and re-attach the wires to connector X3 of CM	Visual check, no tool is required	5 minutes

- 1) This test includes not only the vacuum interrupter test, but also the other insulation components tested in parallel with the interrupter. These include the standoff insulators and the insulated drive links, as well as the insulating (tension) struts between the upper and lower vacuum interrupter supports. If these insulation components are contaminated or defective, the test voltage will not be sustained. If so, clean or replace the affected components, and retest.
- 2) Three phase ISM should be tested phase by phase only. Therefore poles not under the test should be grounded.
- 3) For test of separate ISM - 100% level of test voltage, for test of Switchgear with installed ISM - 80% level of test voltage.
- 4) Rated test voltage levels (Ud) are given in Table 1.
- 5) To apply test voltage single-core short cables should be used. Application of high voltage coaxial cables is strictly prohibited. To coordinate the surge impedance between the test set and ISM extra resistor as shown in the Figure 88 shall be used.
- 6) During testing of vacuum interrupter, self-fading restrikes may appear. In case of restrikes, reduce the voltage slightly until the restrikes disappear (for 10-15 seconds) and then increase again.

Operation description	Required tool	Approximate timing
Primary circuits contact resistance check		
ISM shall be closed before the test, there should not be any external circuits connected to ISM main terminals that provide parallel circuit with the ISM main circuits otherwise tests will be invalid.	Visual check, no tool is required	1 minute
Test equipment shall be connected to ISM main circuits terminals according to Figure 89 in order exclude any additional contact resistance and to decrease measurement error. Main contact resistance shall be measured by appropriate equipment at test current not less than 50 A.	Resistance measurement test equipment with test current not less than 50 A	10 minutes
Measured values for ISM15_LD, ISM25_LD and ISM15_MD must not exceed limits specified in Table 1. Measured values for ISM15_Shell and ISM15_HD must not exceed limits specified in Table 1 increased on 2 μ Ohm. These 2 μ Ohm are added by contact resistance between ISM terminals and additional bars attached to them (see in the Figure 89)	Visual check, no tool is required	-

After above listed tests were performed successfully the ISM can be put into operation.

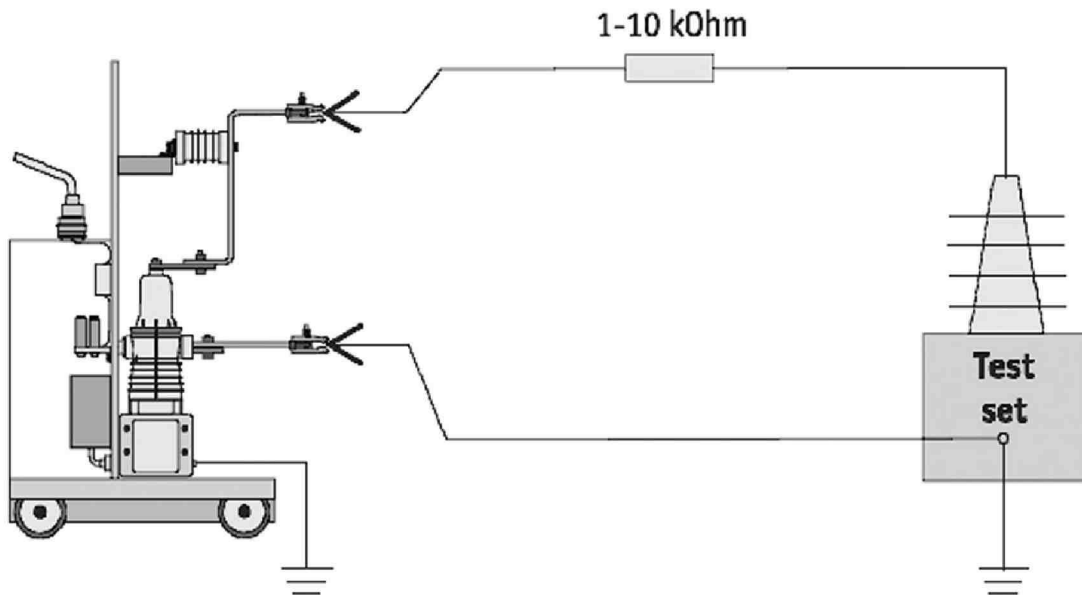

Figure 89

The Vacuum integrity and solid insulation test installation

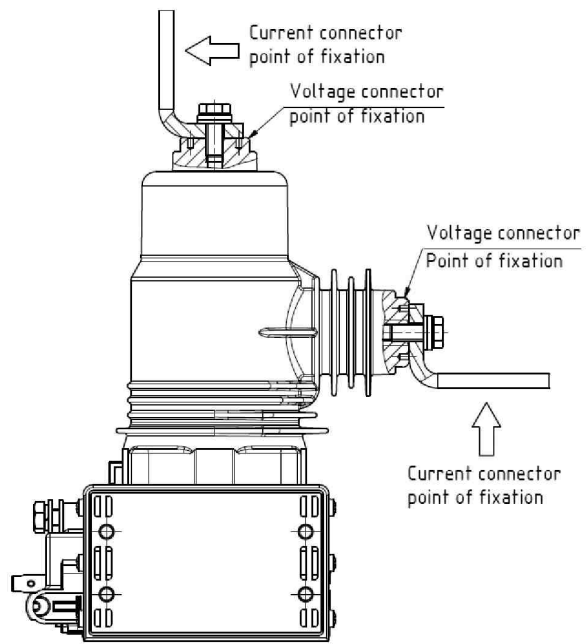

Figure 90

The connection points of the contact resistance meter

6 Operation

6.1 Switching

6.1.1 Closing

To close the ISM main contacts the CM close command shall be applied. It is a “dry contact” input so no external voltage should be applied.

- The Close command will be accepted if:
- CM state is “Ready” (Ready LED flashes green);
- no Trip command is applied;
- optional electrical interlock is unlocked;
- mechanical and electrical interlock is unlocked.

If Close command is applied and held before the CM is in a “Ready” state the Close command will not be accepted. If auxiliary power is not available, the manual generator CBunit_ManGen can be used to charge the CM capacitors and to close the ISM. Mechanical closing is not possible.

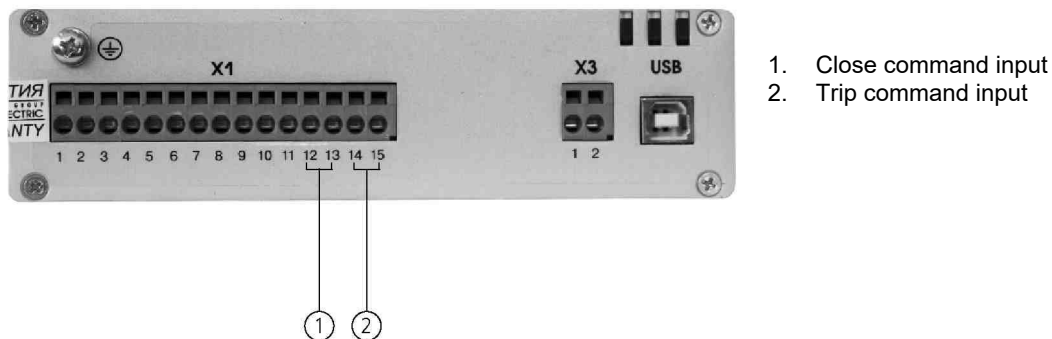

Figure 91

CM_16 close and trip inputs

If Manual generators CBunit_ManGen are used to charge the CM, the Manual generator handle shall be rotated until the Ready LED of the CM flashes green (approximately 30 seconds). Then the ISM close command can be applied to the CM. One possible variant is the connection of NO and Common contacts of relay Ready to the Close command input of the CM. Be aware that in this case the ISM will be closed automatically once the CM reaches the Ready state.

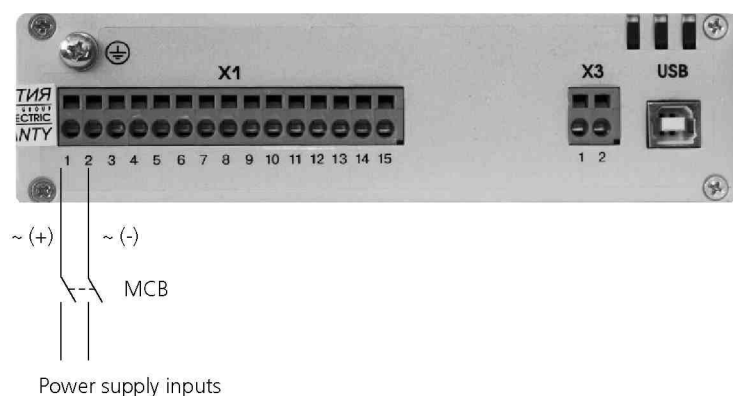

Figure 92

CM_16 power supply connection

If Manual generators CBunit_ManGen are used for charging the CM, DC voltage outputs of the Manual generator shall be connected to the power supply inputs (Figure 91) of CM_16_1. Pay special attention to the correct polarity for CM_16_1(60_2).

6.1.2 Opening

To open the ISM main circuits, a trip command should be applied to the CM trip command input. It is a “dry contact” input so no external voltage should be applied. The trip command will be accepted if:

- CM state is “Ready” (Ready LED flashes green) or within 60 seconds after the removal of the auxiliary power supply;
- optional electrical interlock is unlocked;
- mechanical and electrical interlock is unlocked. If the trip command is applied and kept before the CM is in a “Ready” state, the trip command will not be accepted.

6.1.3 Emergency opening

The ISM can also be opened manually. When the synchronizing shaft is rotated, a force exceeding the magnetic attraction forces of the ring magnet is applied to the armature, which subsequently starts to move. As the air gap increases, the opening springs and the contact pressure springs overcome the magnetic holding force, and the vacuum interrupter opens.

To open the ISM15_MD_1, ISM15_MD_3 manually, the torque shall be applied to the interlocking shaft evenly during its movement - see Figure 92. The torque shall be applied counterclockwise of shaft rotation (90 degrees angle). The torque shall not be applied at the end of shaft rotation. ISM15_MD_1, ISM15_MD_3, have a built in electrical interlock that interrupts the ISM coil circuit after the interlocking shaft is rotated counterclockwise. After manual trip, the shaft should be rotated clockwise to unlock the ISM.

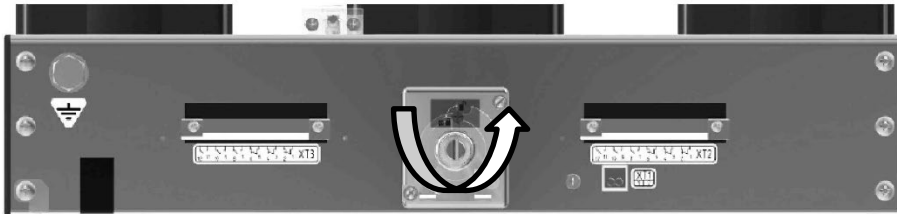

Figure 93

ISM15_MD_1 manual trip

7 Maintenance and troubleshooting

7.1 Primary circuits

Under normal operating conditions (see Table 1) the ISM is maintenance free for a period of at least 30 years or until it has reached the permissible number of operating cycles.

However when maintenance is carried out on the switchgear then the commissioning tests should be repeated. Check that the ISM is disconnected from all voltage sources before inspecting its insulating parts. Test results should be treated as given in Table 17.

Table 18 - List of tests and check-ups of ISM during maintenance

Operation description	Required tool	Approximate timing
Check for damage, remove any dirt, contamination or moisture	Dry napless cloth or a napless cloth soaked in alcohol to clean the insulation	5 minutes
Bolts and torques shall be according to Figure 37	Torque wrench according to torque value	2 minutes
Protective earthing shall be according to subchapter 4.1.6	Wrench if required	1 minute
ISM operation check		
Perform close and open operation of the ISM. Modules shall be operable. Otherwise, check the control circuit. If necessary, change the failed module.	Visual check, no tool is required	1 minute
Primary circuits insulation check¹⁾		
Observe safety precautions listed in the danger and warning advisories. Construct the proper barrier and warning light system	Equipment to provide safety in test area	10 minutes
Ground each pole not under test	Wires	2 minutes
Apply slowly rising 100% ²⁾ of test voltage ³⁾ (50 or 60 Hz) across each pole for one minute ⁴⁾ . (ISM is open)	Power frequency withstand voltage test set	2 minutes
If the pole sustains the test voltage for that period, its vacuum integrity has been verified ⁵⁾	Power frequency withstand voltage test set	-
Repeat actions above to check each pole of the ISM	Power frequency withstand voltage test set, wires	8 minutes
Close the ISM. Ground each pole not under test	Wires	1 minute
Apply slowly rising 80% of test voltage ²⁾ (50 or 60 Hz) between a primary conductor of the pole and ground for one minute, repeat test for each pole of ISM	Power frequency withstand voltage test set	12 minutes
If no disruptive discharge occurs, the insulation system is satisfactory	Power frequency withstand voltage test set	-
After the test, ground all main circuit terminals to dissipate any static charge	Wires	2 minutes

- 1) This test includes not only the vacuum interrupter test, but also the other insulation components tested in parallel with the interrupter. These include the support insulators and the insulated drive links, as well as the insulating (tension) struts between the upper and lower vacuum interrupter supports. If these insulation components are contaminated or defective, the test voltage will not be sustained. If so, clean or replace the affected components, and retest.
- 2) For test of separate ISM – 100% of test voltage according to C37.09 - 100% level of test voltage, for test of Switchgear with installed ISM - 80% level of test voltage.
- 3) Rated test voltage levels (Ud) are given in Table 1 above.
- 4) To apply test voltage the single-core short cables should be used. Application of high voltage coaxial cables is strictly prohibited. To coordinate the surge impedance between the test set and ISM extra resistor as shown in Figure 88 shall be used.
- 5) During testing of vacuum interrupter, self-fading restrikes may appear. In case of restrikes, reduce the voltage slightly until the restrikes disappear (for 10-15 seconds) and then increase again.

Operation description	Required tool	Approximate timing
Primary circuits contact resistance check¹⁾		
ISM shall be closed before the test, there should not be any external circuits connected to ISM main terminals that provide parallel circuit with the ISM main circuits otherwise tests will be invalid.	Visual check, no tool is required	1 minute
Test equipment shall be connected to ISM main circuits terminals according to Figure 89 in order exclude any additional contact resistance and to decrease measurement error. Main contact resistance shall be measured by appropriate equipment at test current not less than 50 A.	Resistance measurement test equipment with test current not less than 50 A	10 minutes
Measured values for ISM15_LD, ISM25_LD and ISM15_MD must not exceed limits specified in Table 1 ¹⁾ Measured values for ISM15_Shell and ISM15_HD must not exceed limits specified in Table 1 increased on 2 μOhm. These 2 μOhm are added by contact resistance between ISM terminals and additional bars attached to them (see in the Figure 89)	Visual check, no tool is required	-

- 1) If the Module has contact resistance which exceeds the specified limit but is less than twice this limit, continuation of use is possible, if actual continuous current does not exceed the following value:

$$I_a < I_r \sqrt{\frac{R_r}{R_a}}$$

where:

I_a, R_a — actual current and corresponding contact resistance,

I_r, R_r — rated values (Table 1).

If the contact resistance is at least twice as high as the specified limit, the ISM must be replaced.

Additionally switchboards can be subjected to extra tests that are specified in corresponding documentation for the switchboards.

7.2 Secondary circuits

The CM is inherently maintenance free. However when maintenance is carried out on the switchgear then commissioning tests should be repeated. It is also recommended to conduct regular visual checks of the module housing and insulation of the wires connected to the CM. Test results should be treated as given in the Table 18.

Table 19 - List of tests and check-ups of CM during maintenance

Operation description	Required tool	Approximate timing
	Auxiliary circuits insulation check	
Connect all points of the secondary circuits with a shorting wire. ISM coil connection wires must be disconnected from connector X3 of the CM before the test.	Wires	5 minutes
Connect the shorting wire to the high potential lead of the high voltage tester and ground the circuit breaker housing. Start with zero volts, gradually increase the test voltage to 2000 V RMS, 50 or 60 Hz. Maintain test voltage for one minute.	Power frequency withstand voltage test set	3 minutes
If no disruptive discharge occurs, the secondary circuits insulation level is satisfactory.	Power frequency withstand voltage test set	-
Disconnect the shorting wire and reattach the wires to connector X3 of the CM.	Visual check, no tool is required	5 minutes

7.3 Troubleshooting

If during installation, commissioning, operation or maintenance any non-conformity occurs, contact your nearest Tavrida Electric sales representative. The contact data and web site links are listed at the end of this document. In case of a non-conformity any repairs are strictly prohibited without permission from the sales representative. To be sure that a non-conformity occurred, please perform the checks as mentioned in Table 19 prior to contacting our regional representative.

Table 20 - Typical fault symptoms and methods of their elimination

Failure description	Possible reason	Method of elimination
Appearance failure	Mechanical or arc damage, breach of service conditions	Replacement of failed component
Excessive contact resistance of ISM	ISM reached the permissible number of operating cycles or decreasing of insulation level in ISM vacuum interrupters	Replacement of ISM
ISM cannot pass power frequency voltage withstand test at 80 % of rated voltage	ISM vacuum interrupters or insulation damage	Replacement of ISM
ISM cannot perform close/trip operation	ISM is interlocked	Check ISM interlock state and its actuator coil connection with connector X3 of CM
	CM failure	Check CM LED states
	Mechanical damage of ISM	Replacement of ISM
1 blink of CM "Malfunction" LED	Absence of CM power supply	Check presence of CM power supply, its polarity and voltage level
2 blinks of CM "Malfunction" LED	ISM cannot be closed / tripped	Check the circuit of ISM actuator coil connection with connector X3 of CM, check state of ISM electrical interlocks
3 blinks of CM "Malfunction" LED	ISM actuator coil circuit is interrupted	Check the circuit of ISM actuator coil connection with connector X3 of CM, check state of ISM electrical interlocks
4 blinks of CM "Malfunction" LED	Short circuit of ISM actuator coil circuit	Check the circuit of ISM actuator coil connection with connector X3 of CM, check state of ISM electrical interlocks
5 blinks of CM "Malfunction" LED	Manual trip of ISM and ISM is electrically interlocked	Check the ISM and its interlock state
6 blinks of CM "Malfunction" LED	CM is out of the temperature range	Stop performing CO operations until the blinks stop if temperature is above the temperature range or move CM into environment with higher temperature if temperature is below the temperature range.
7 blinks of CM "Malfunction" LED	ISM state is open without command from the CM	Check the ISM and its interlock state
CM "Malfunction" LED lights continuously	Internal fault of CM	Replacement of CM
None of CM LEDs lights	Absence of CM power supply	Check presence of CM power supply, its polarity and voltage level
	Internal fault of CM	Replacement of CM

The ISM or CM removal and the installation of the new one should be performed according to chapter 0. The checks and tests after substitution are described in chapter 5.

8 Disposal

All Tavrida Electric Vacuum Circuit Breakers and their components are manufactured from environmentally friendly materials, therefore no special waste disposal is required.

Appendix 1. ISM package dimensions and weights

ISM package dimensions and weights

ISM	Package dimensions, not more than (LxWxH), mm	Gross weight, not more than, kg
TNA_ISM15_MD_1	760x315x490	41.5
TNA_ISM15_MD_3	300x315x490	16.1

Appendix 2: Overall Drawings

Dimensions of Indoor Switching Modules

Dimensions in millimeters:

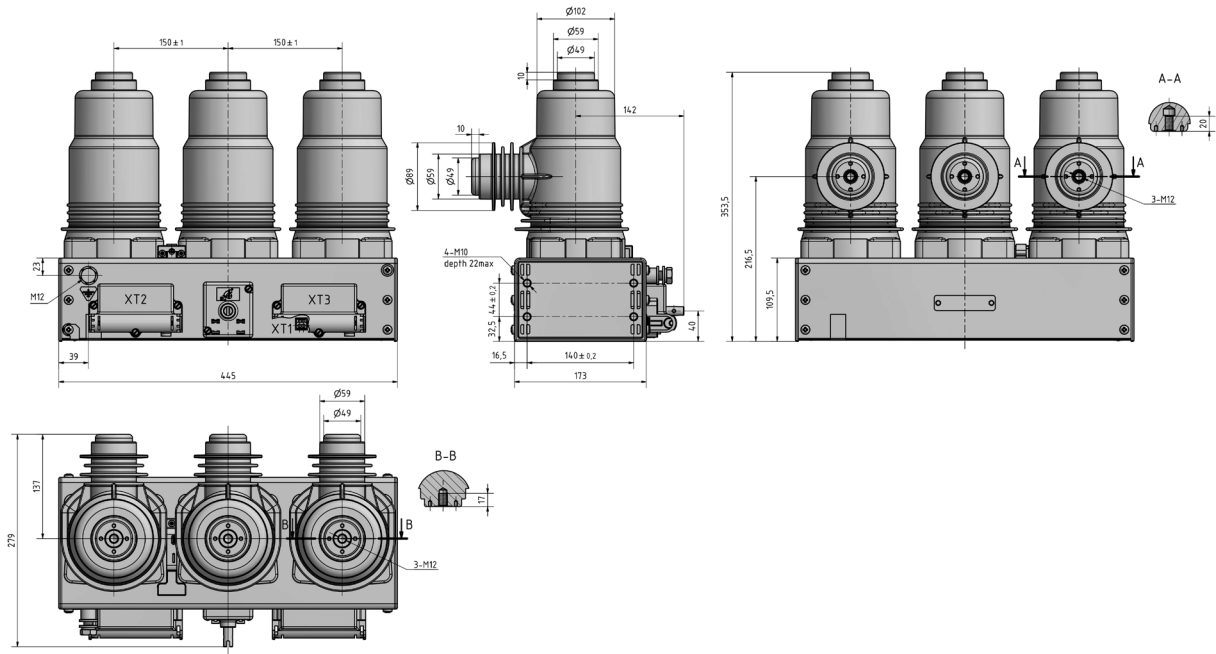

Dimensions in inches:

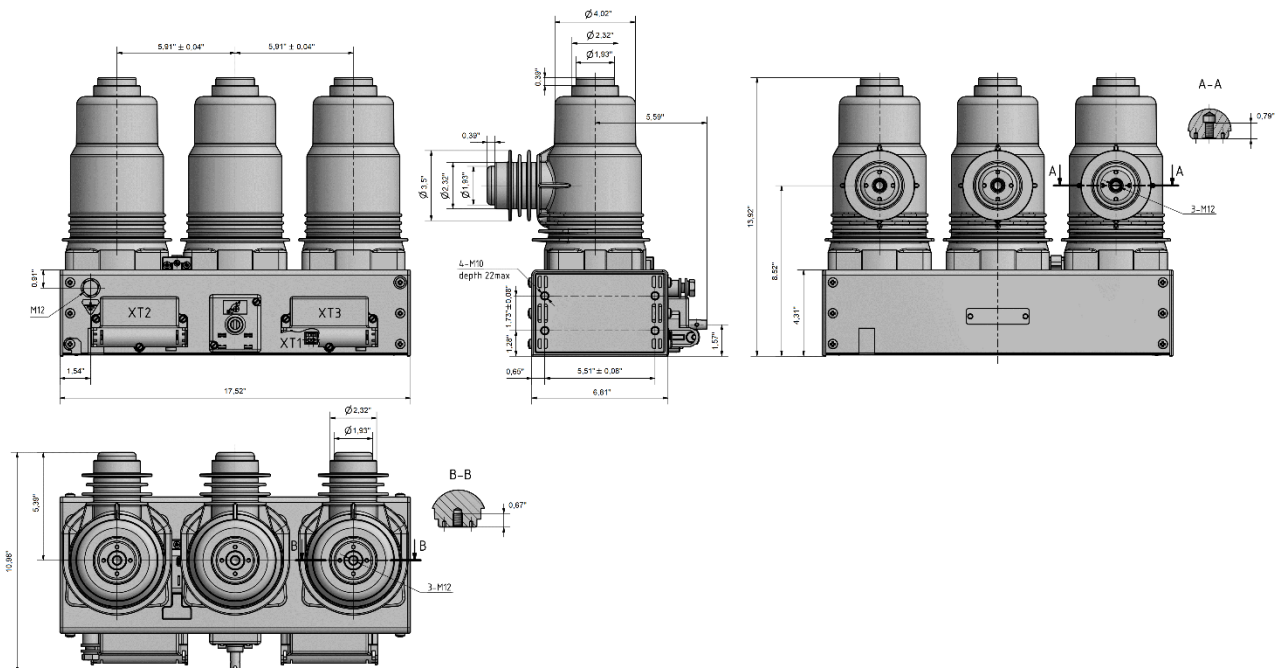

**ISM15_MD_1(150_L) dimensions in millimeters ,
PCD 150 mm,
Weight: 72,75 lbs**

Dimensions in millimeters:

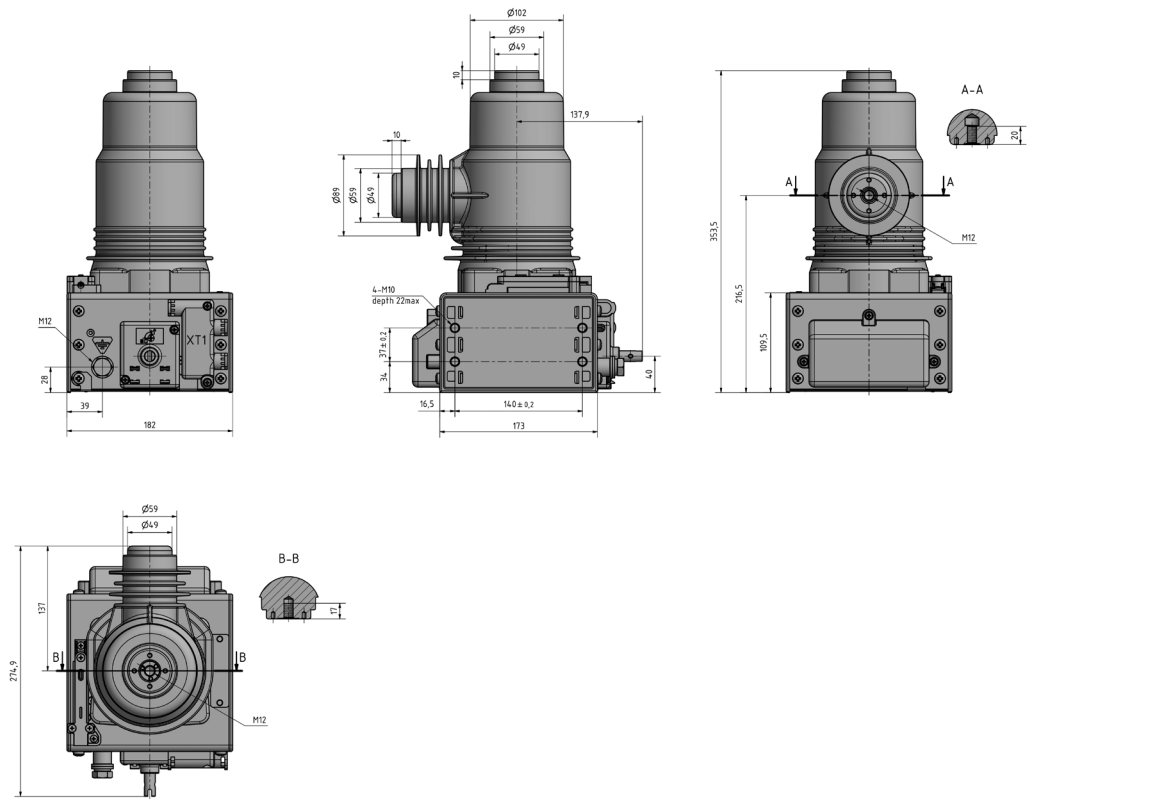

Dimensions in inches:

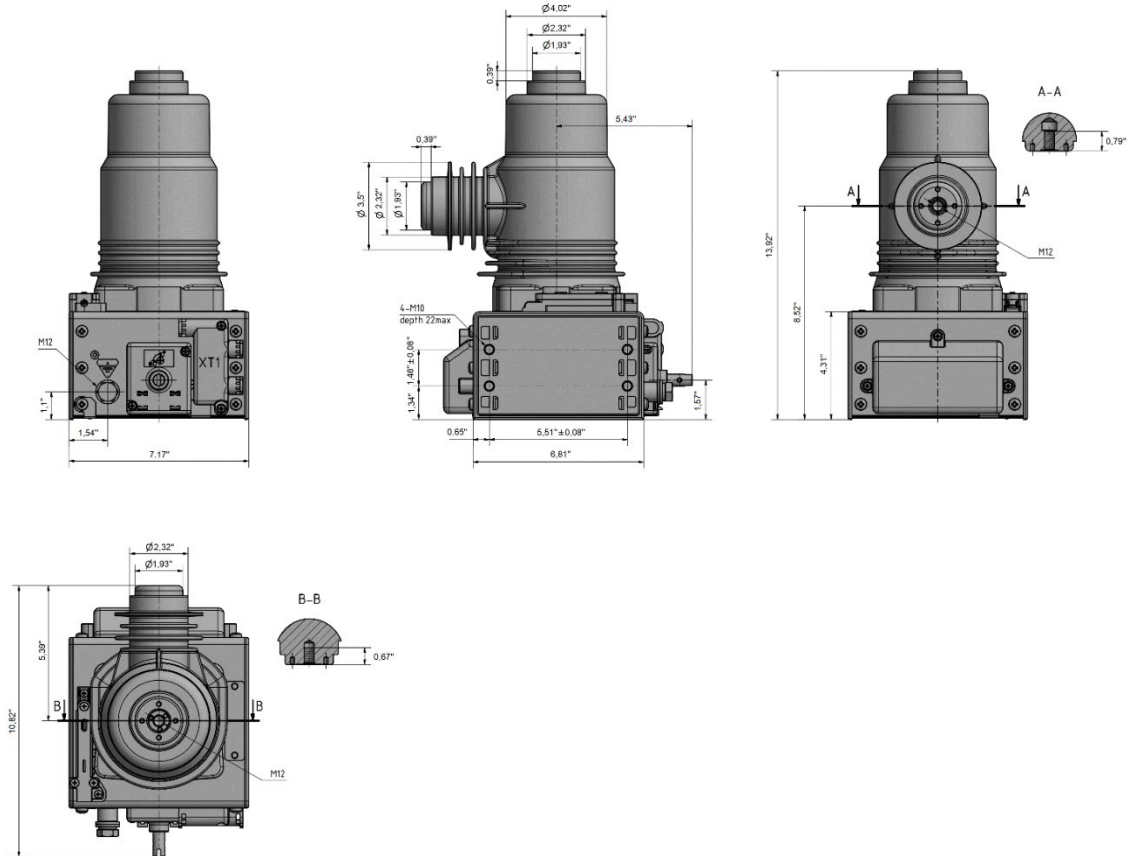

ISM15_MD_3,
Weight: 28,66 lbs

Dimensions of Control Module

Dimensions in millimeters:

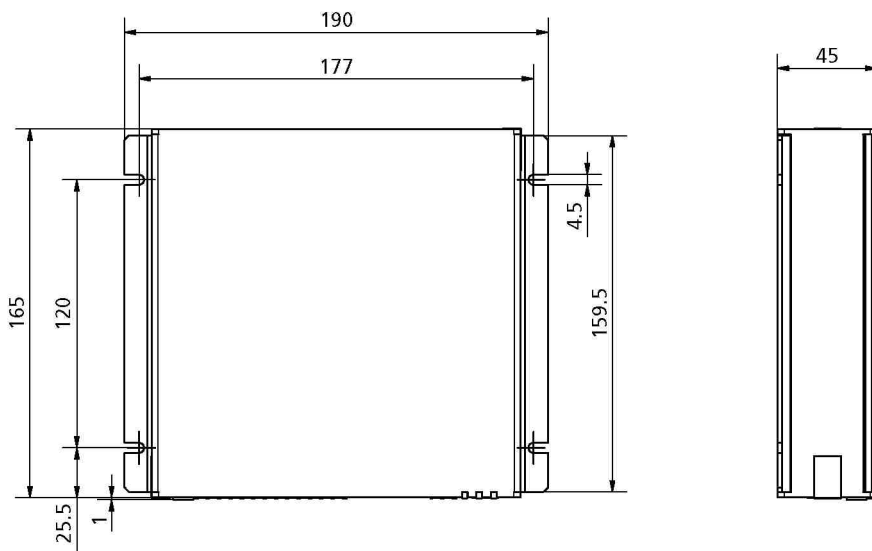
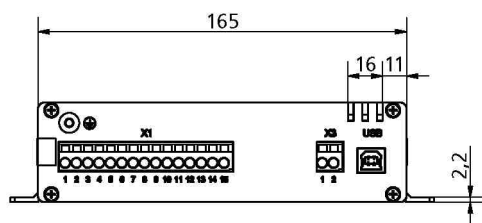

CM_16_1
Weight: 1 kg

Dimensions in inches:

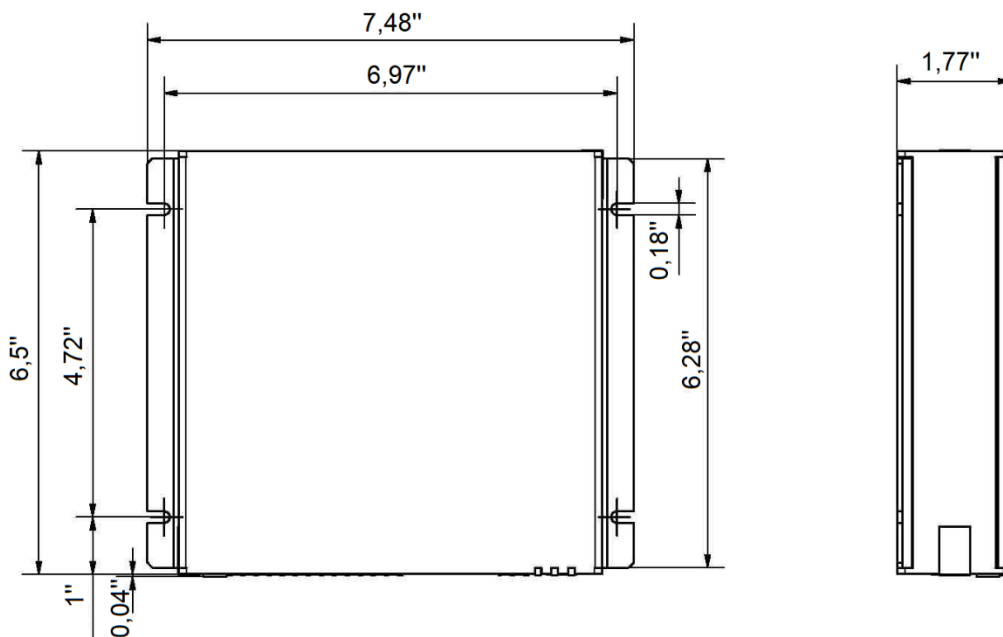
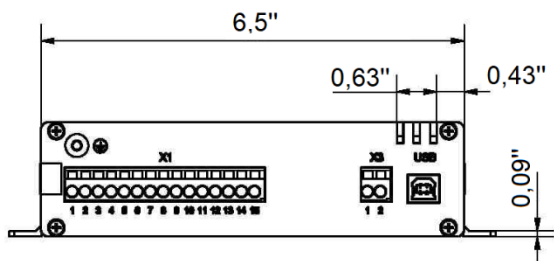

CM_16_1
Weight: 2,2 lbs

Dimensions of accessories

Dimensions of Position Indicator (*CBkit_PosInd_1*) in millimeters

Rope length $L=1m$

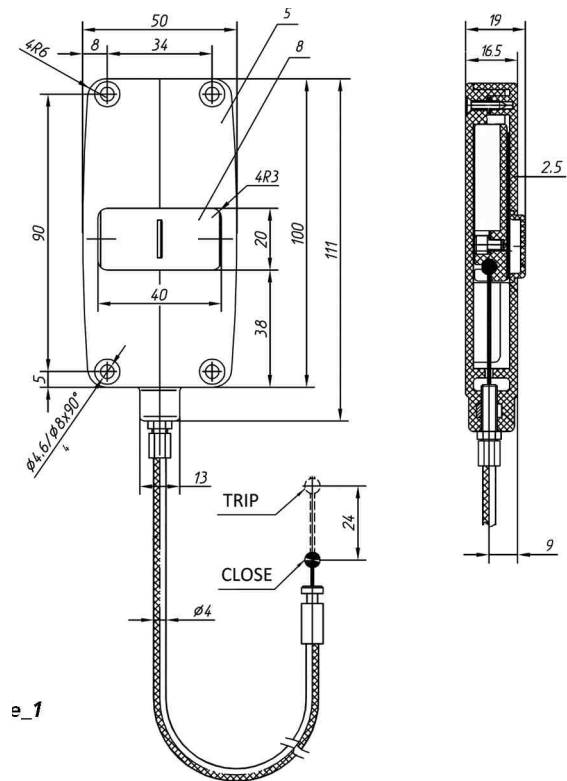

e_1

Dimensions of Position Indicator (*CBkit_PosInd_1*) in inches

Rope length $L= 39,37''$

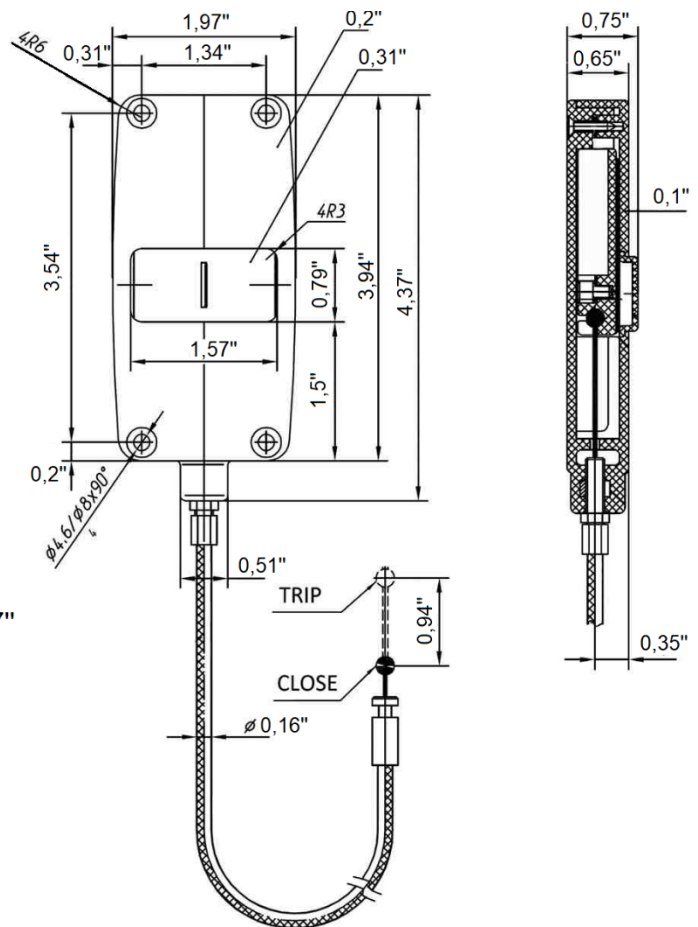

Dimensions of Manual Generator in millimeters:

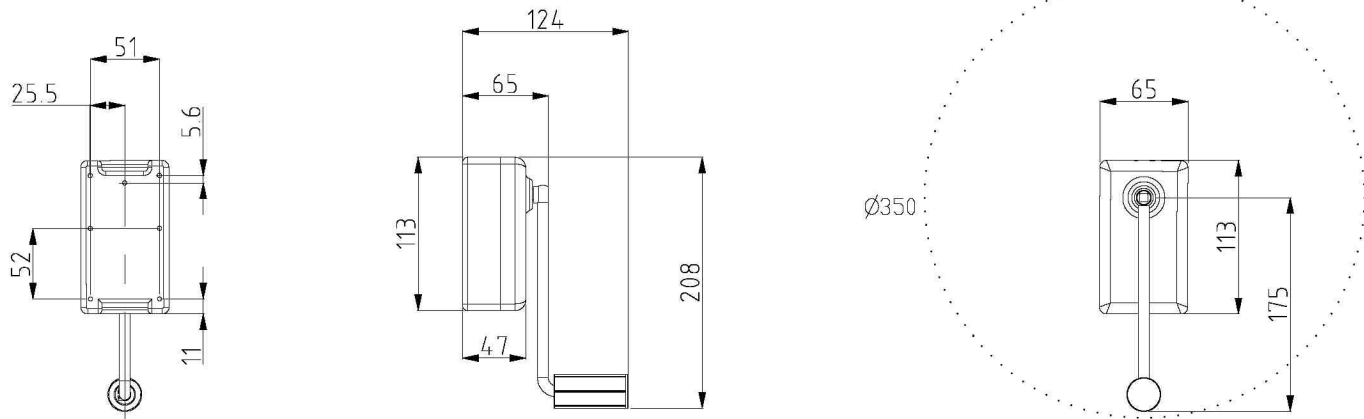

CBunit_ManGen_1, CBunit_ManGen_2

Dimensions of Manual Generator in inches:

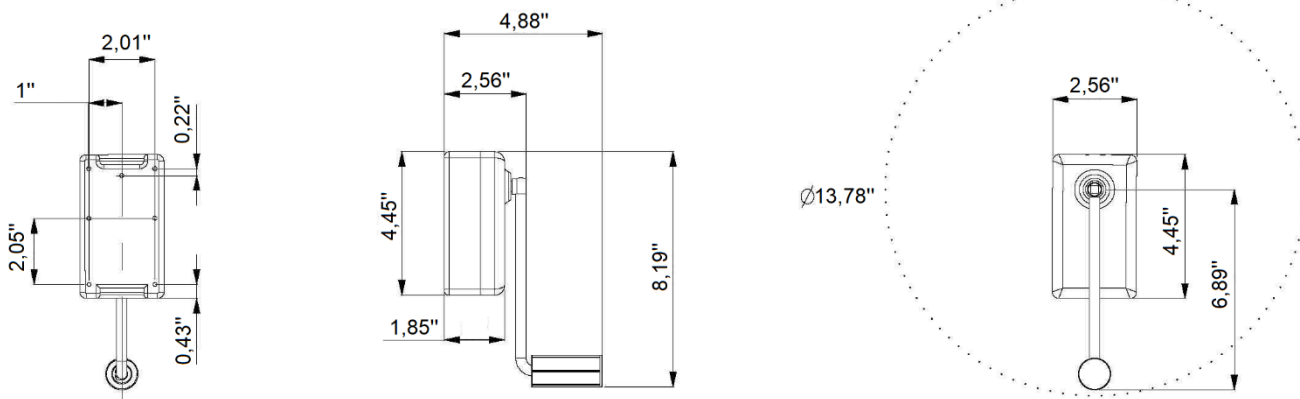

CBunit_ManGen_1, CBunit_ManGen_2

Dimensions of Interlocking Kits

Dimensions of CBkit_Interlock_3 in millimeters:

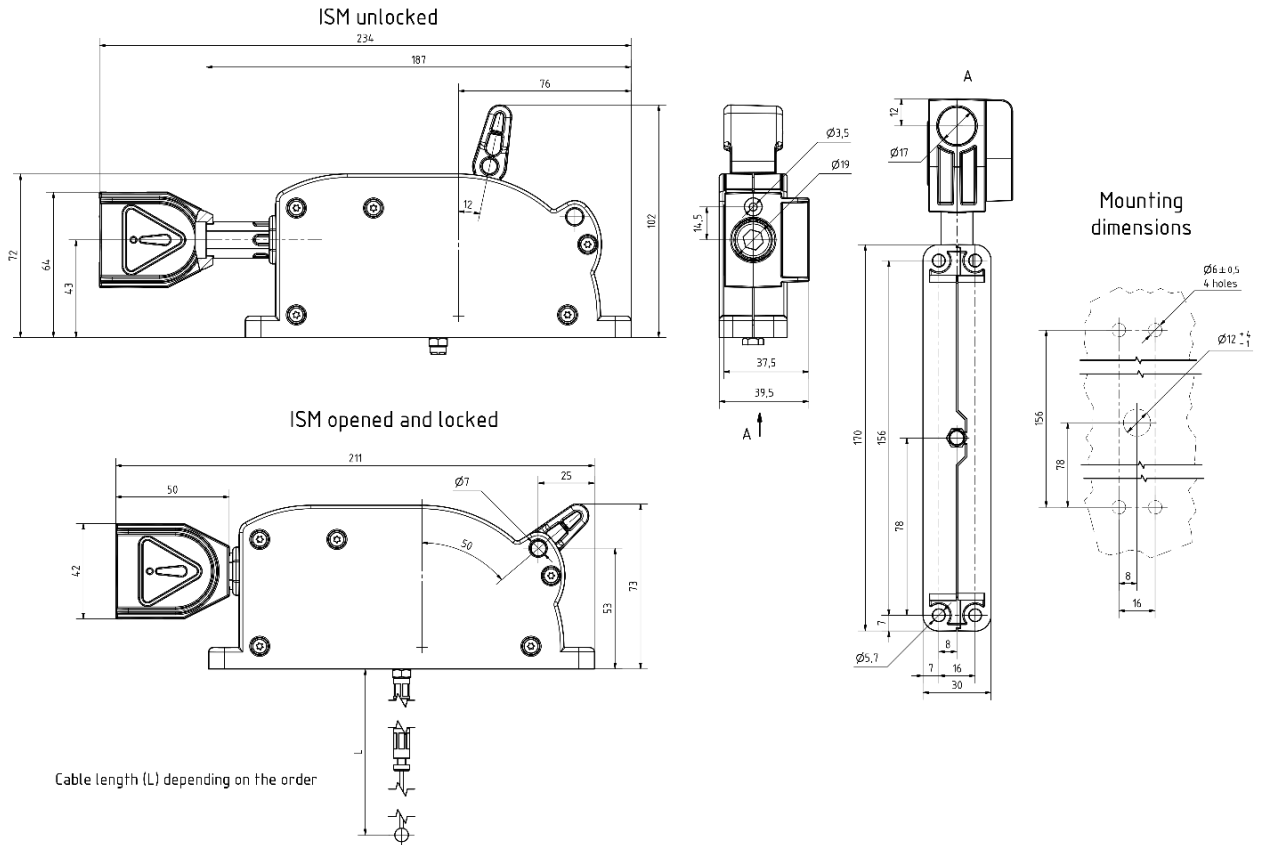

CBkit_Interlock_3

Dimensions of CBkit_Interlock_3 in inches:

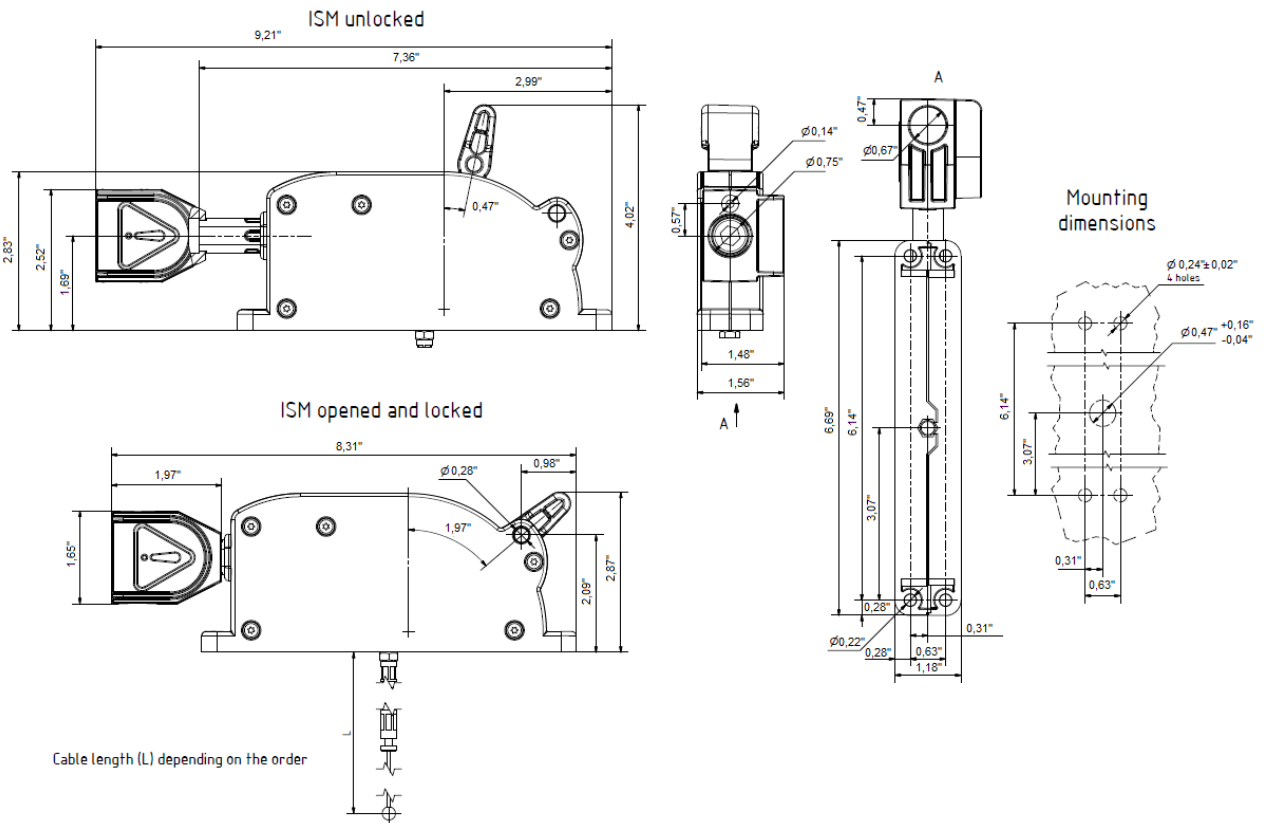

CBkit_Interlock_3

Dimensions of CBkit_Interlock_4 in millimeters:

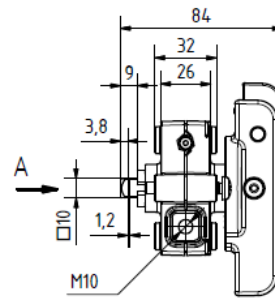
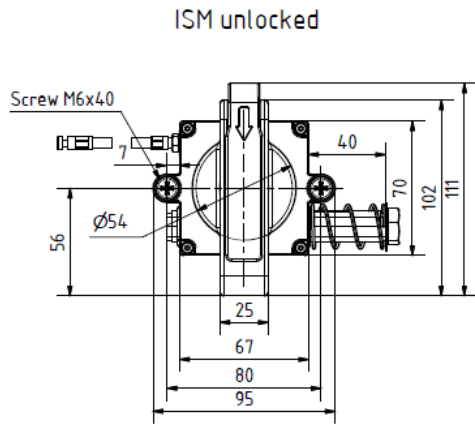

ISM opened and locked

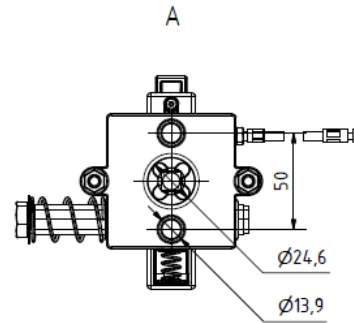
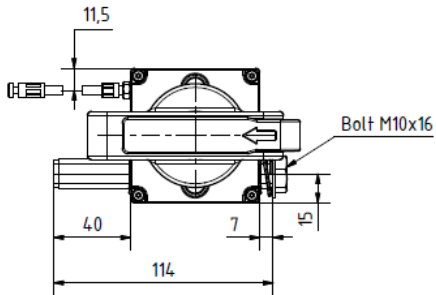

Cable length (L) depending on the order

CBkit_Interlock_4

Dimensions of CBkit_Interlock_4 in inches:

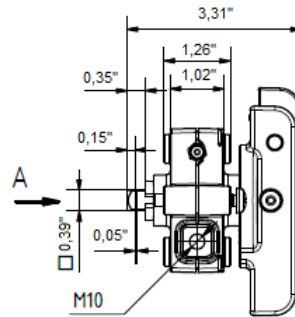
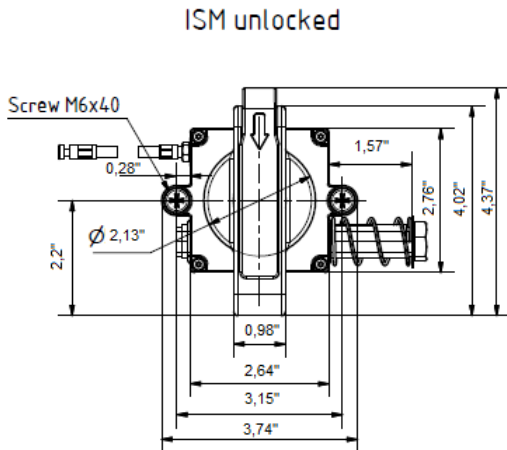

ISM opened and locked

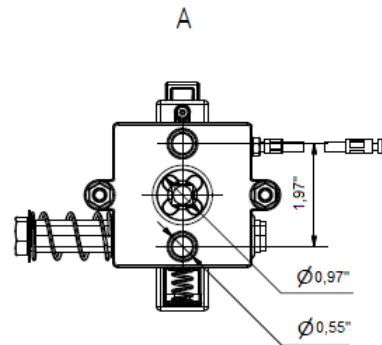
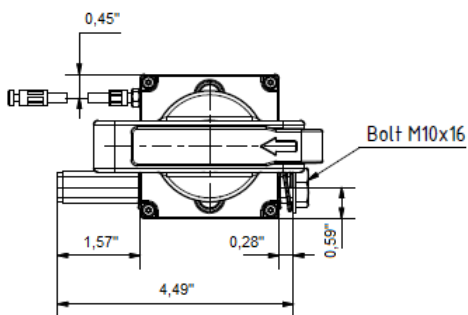

Cable length (L) depending on the order

CBkit_Interlock_4

Dimensions of CBkit_Interlock_5 in millimeters:

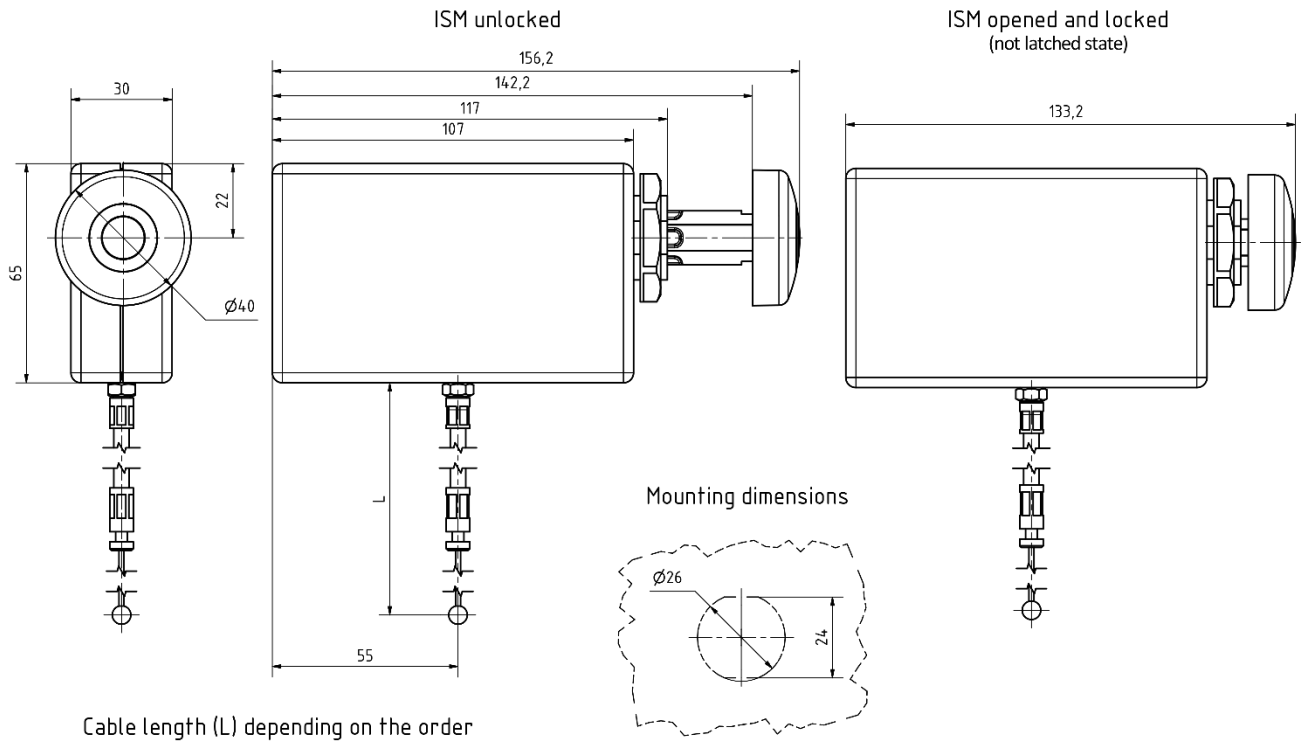

CBkit_Interlock_5

Dimensions of CBkit_Interlock_5 in inches:

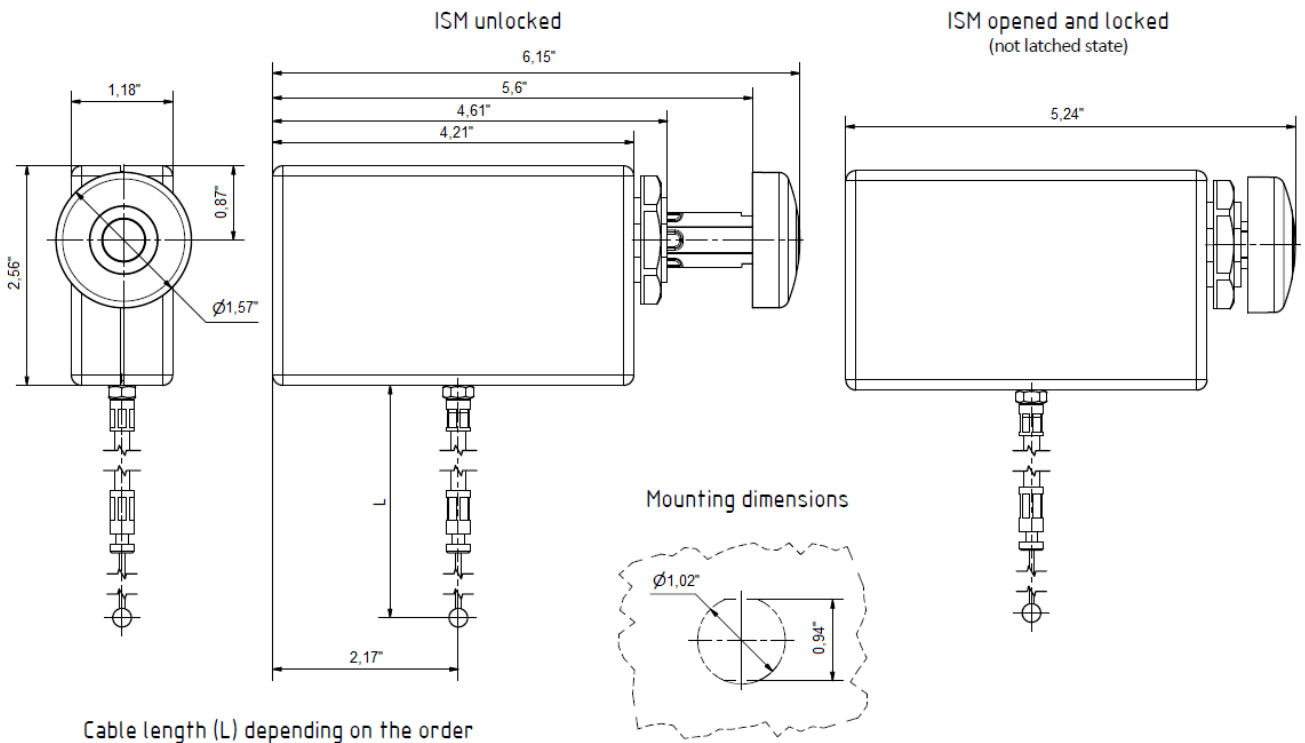

CBkit_Interlock_5

Appendix 3: Secondary Schemes

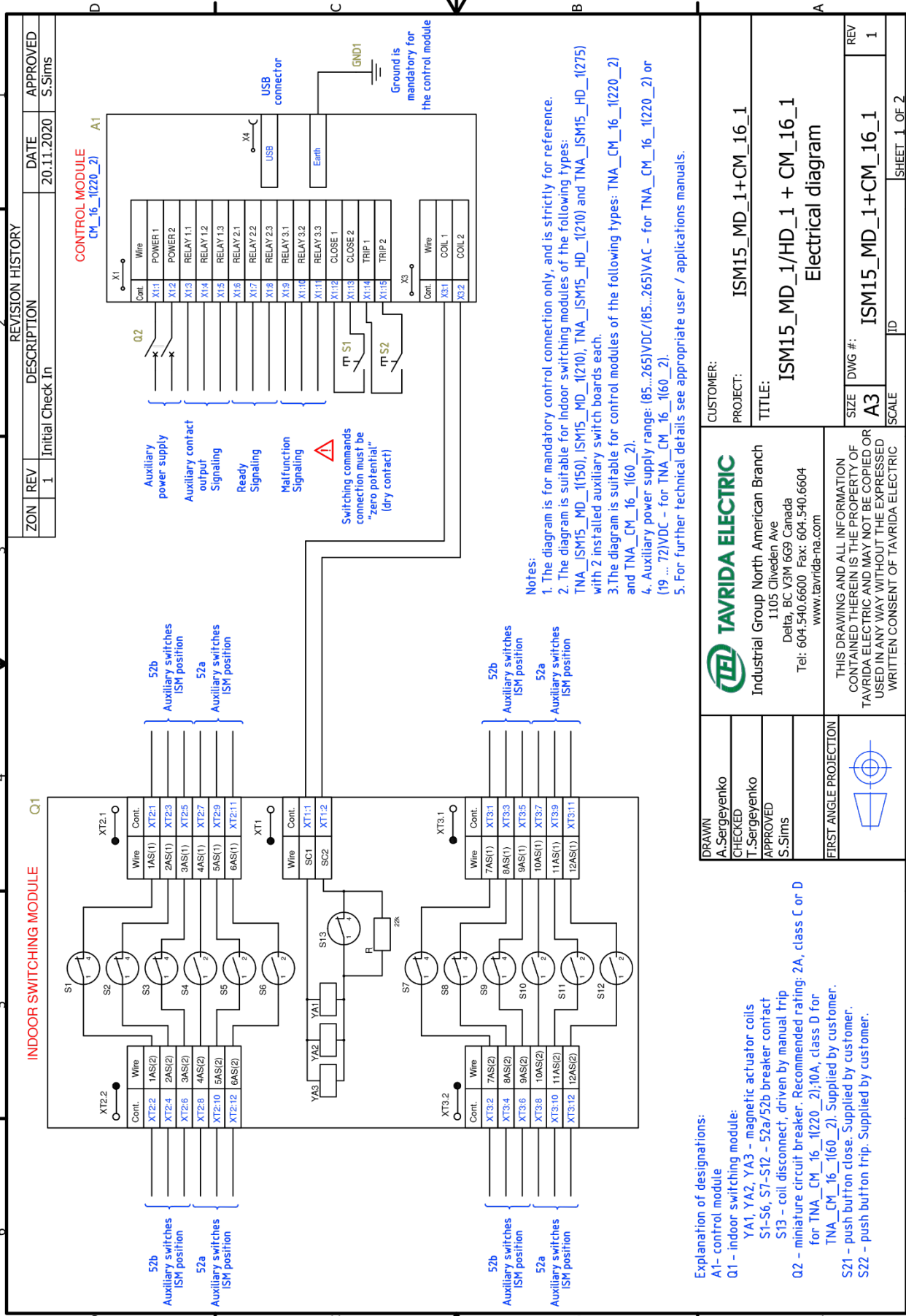

ZON	REV	DESCRIPTION	DATE	APPROVED
	1	Initial Check In	20.11.2020	S.Sims

CONTROL MODULE
CM_16_1(220_2) A1

INDOOR SWITCHING MODULE
Q1

- Notes:**
- The diagram is for mandatory control connection only, and is strictly for reference.
 - The diagram is suitable for indoor switching modules of the following types: TNA_ISM15_MD_1(150), ISM15_MD_1(210), TNA_ISM15_HD_1(210) and TNA_ISM15_HD_1(275) with 2 installed auxiliary switch boards each.
 - The diagram is suitable for control modules of the following types: TNA_CM_16_1(220_2) and TNA_CM_16_1(60_2).
 - Auxiliary power supply range: (85...265)VDC/(85...265)VAC - for TNA_CM_16_1(220_2) or (19...72)VDC - for TNA_CM_16_1(60_2).
 - For further technical details see appropriate user / applications manuals.

- Explanation of designations:**
- A1- control module
 - Q1 - indoor switching module:
 - YA1, YA2, YA3 - magnetic actuator coils
 - S1-S6, S7-S12 - 52a/52b breaker contact
 - S13 - coil disconnect, driven by manual trip - Q2 - miniature circuit breaker. Recommended rating: 2A, class C or D for TNA_CM_16_1(220_2); 10A, class D for TNA_CM_16_1(60_2). Supplied by customer.
 - S21 - push button close. Supplied by customer.
 - S22 - push button trip. Supplied by customer.

TAVRIDA ELECTRIC
Industrial Group North American Branch
1105 Cliveden Ave
Delta, BC V3M 6G9 Canada
Tel: 604-540-6600 Fax: 604-540-6604
www.tavrída-na.com

CUSTOMER:	ISM15_MD_1+CM_16_1
PROJECT:	ISM15_MD_1/HD_1 + CM_16_1
TITLE:	Electrical diagram
SIZE	A3
DWG #:	ISM15_MD_1+CM_16_1
SCALE	1
ID	2
SHEET	1 OF 2

THIS DRAWING AND ALL INFORMATION CONTAINED THEREIN IS THE PROPERTY OF TAVRIDA ELECTRIC AND MAY NOT BE COPIED OR USED IN ANY WAY WITHOUT THE EXPRESSED WRITTEN CONSENT OF TAVRIDA ELECTRIC



REVISION HISTORY		DATE	APPROVED
ZON	REV	DESCRIPTION	
	1	Initial Check in	S.Simis

Notes:
 The CM_16 series control modules have three latching output relays in an SPDT configuration. Each relay can be factory programmed for one of three functions per the chart below. See the settings code label on the right side of the CM_16 module for as-shipped relay configuration.
 The relays will change state from unasserted to asserted based on the firmware logic as outlined in the chart below. Note that as the relays are latching types they will retain their last state (asserted or unasserted) after power loss and complete discharge of the module capacitor bank.

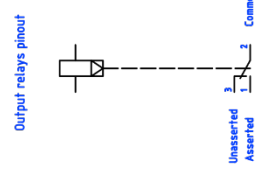
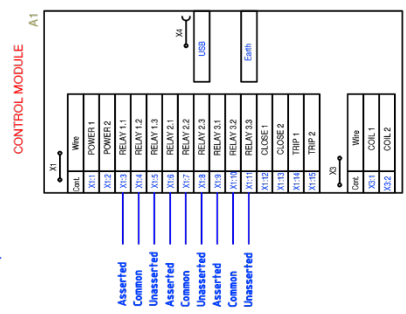

Relay programmed Function	Relay reaction to Control / Breaker Events			
	Breaker Open	Breaker Closed	Malfunction	Trip on Loss of Supply
Ready (Indication whether breaker is open or closed)	Unasserted	Asserted	NO EFFECT	NO EFFECT
Ready (Indication that the control module is ready to perform close operation)	NO EFFECT	NO EFFECT	Unasserted	Asserted
Malfunction (Indication that there is an error; all close operations blocked until corrected)	NO EFFECT	NO EFFECT	Asserted	Unasserted
UV Active (Indication that trip on loss of supply occurred. Available if UV is set "on")	NO EFFECT	NO EFFECT	NO EFFECT	Asserted
Loss of Supply (Indication if control module has no power supply)	NO EFFECT	NO EFFECT	NO EFFECT	Asserted
Malfunction or Loss of Supply (Indication that there is an error or loss of power; all close operations blocked until corrected)	NO EFFECT	NO EFFECT	Asserted	Asserted
Disabled (Relays disabled and will not change state for any event)	NO EFFECT	NO EFFECT	NO EFFECT	NO EFFECT

Note:
 x - asserted while power supply is lost but unasserted when power supply returns back on
 See Applications Manual for detailed description of "Malfunction", "Ready to Close" and "Trip on Loss of Supply" events.

DRAWN A.Sergeyenko		CUSTOMER: ISM15_MD_1+CM_16_1	
CHECKED T.Sergeyenko		PROJECT: ISM15_MD_1+CM_16_1	
APPROVED S.Simis		TITLE: ISM15_MD_1/HD_1 + CM_16_1 Electrical diagram	
FIRST ANGLE PROJECTION		SIZE A2	
		DWG #: ISM15_MD_1+CM_16_1	
<p>THIS DRAWING AND ALL INFORMATION CONTAINED THEREIN IS THE PROPERTY OF TAVRIDA ELECTRIC AND MAY NOT BE COPIED OR REPRODUCED IN ANY MANNER WITHOUT WRITTEN CONSENT OF TAVRIDA ELECTRIC</p>		SCALE 1	
<p>Industrial Group North American Branch 1105 Chiveden Ave Delta, BC V3M 6G9 Canada Tel: 604.540.6600 Fax: 604.540.6604 www.tavrda-na.com</p>		SHEET 2 OF 2	

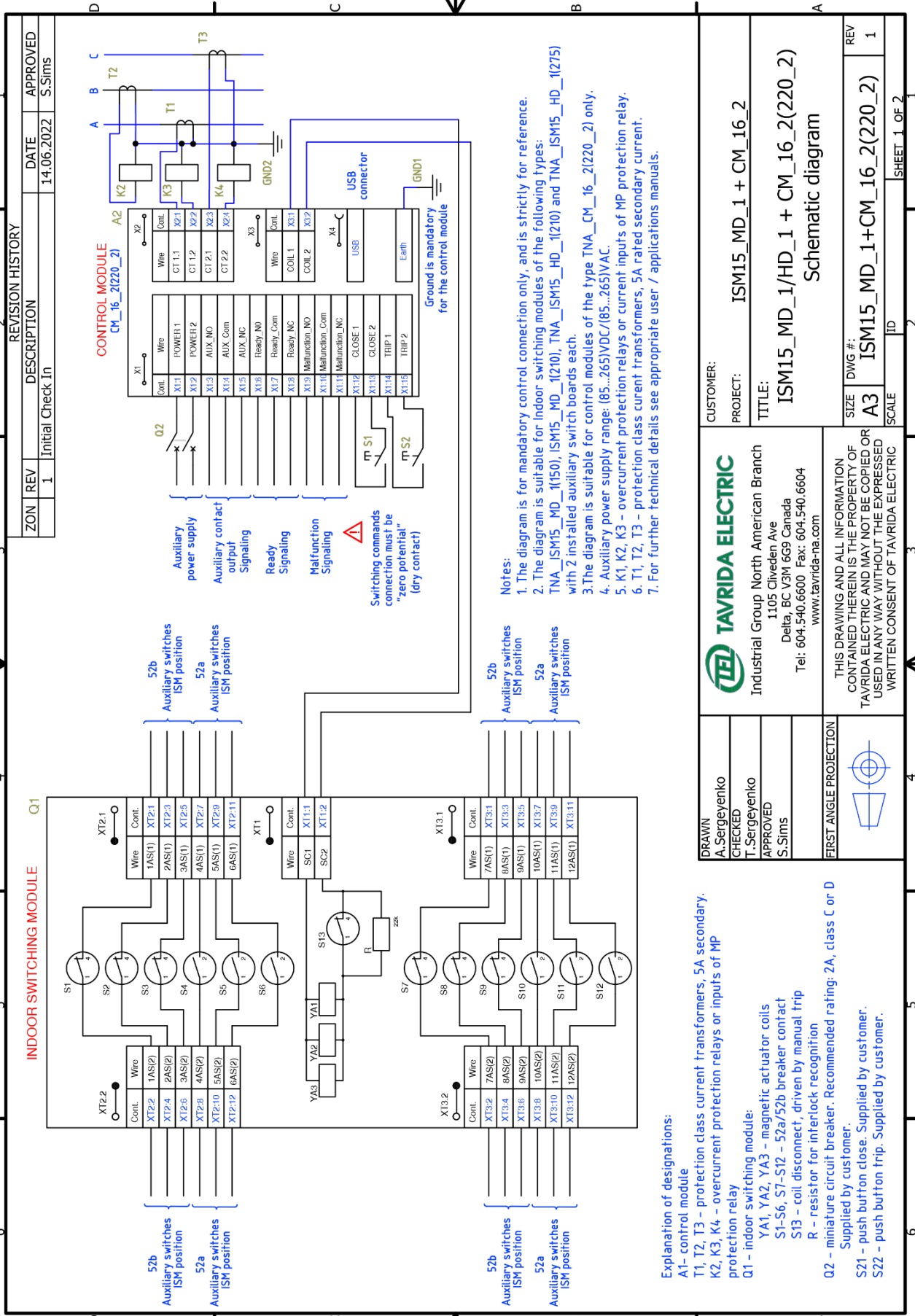

ZON	REV	DESCRIPTION	DATE	APPROVED
	1	Initial Check In	14.06.2022	S.Sims

REVISION HISTORY
CM_16_21220_2

WIRE	CONT.
X1	POWER1.1
X2	POWER1.2
X3	AUX_NO
X4	AUX_COM
X5	AUX_NC
X6	Ready_NO
X7	Ready_COM
X8	Ready_NC
X9	Multifunction_NO
X10	Multifunction_COM
X11	Multifunction_NC
X12	CLOSE 1
X13	CLOSE 2
X14	TRIP 1
X15	TRIP 2

WIRE	CONT.
X16	USB
X17	Earth

WIRE	CONT.
X18	1AS(1)
X19	2AS(1)
X20	3AS(1)
X21	4AS(1)
X22	5AS(1)
X23	6AS(1)
X24	7AS(1)
X25	8AS(1)
X26	9AS(1)
X27	10AS(1)
X28	11AS(1)
X29	12AS(1)
X30	1AS(2)
X31	2AS(2)
X32	3AS(2)
X33	4AS(2)
X34	5AS(2)
X35	6AS(2)
X36	7AS(2)
X37	8AS(2)
X38	9AS(2)
X39	10AS(2)
X40	11AS(2)
X41	12AS(2)

WIRE	CONT.
X42	SC1
X43	SC2
X44	XT11.1
X45	XT11.2
X46	XT13.1
X47	XT13.2
X48	XT13.3
X49	XT13.4
X50	XT13.5
X51	XT13.6
X52	XT13.7
X53	XT13.8
X54	XT13.9
X55	XT13.10
X56	XT13.11

WIRE	CONT.
X57	CT1.1
X58	CT1.2
X59	CT2.1
X60	CT2.2

WIRE	CONT.
X61	CT1.1
X62	CT1.2
X63	CT2.1
X64	CT2.2

WIRE	CONT.
X65	CT1.1
X66	CT1.2
X67	CT2.1
X68	CT2.2

WIRE	CONT.
X69	COIL 1
X70	COIL 2
X71	X31
X72	X32

WIRE	CONT.
X73	COIL 1
X74	COIL 2
X75	X31
X76	X32

WIRE	CONT.
X77	COIL 1
X78	COIL 2
X79	X31
X80	X32

WIRE	CONT.
X81	USB
X82	Earth

WIRE	CONT.
X83	USB
X84	Earth

WIRE	CONT.
X85	USB
X86	Earth

WIRE	CONT.
X87	Earth

WIRE	CONT.
X88	Earth

WIRE	CONT.
X89	Earth

WIRE	CONT.
X91	Earth

WIRE	CONT.
X92	Earth

WIRE	CONT.
X93	Earth

WIRE	CONT.
X95	Earth

WIRE	CONT.
X96	Earth

WIRE	CONT.
X97	Earth

WIRE	CONT.
X99	Earth

WIRE	CONT.
X100	Earth

WIRE	CONT.
X101	Earth

WIRE	CONT.
X103	Earth

WIRE	CONT.
X104	Earth

WIRE	CONT.
X105	Earth

WIRE	CONT.
X107	Earth

WIRE	CONT.
X108	Earth

WIRE	CONT.
X109	Earth

WIRE	CONT.
X111	Earth

WIRE	CONT.
X112	Earth

WIRE	CONT.
X113	Earth

WIRE	CONT.
X115	Earth

WIRE	CONT.
X116	Earth

WIRE	CONT.
X117	Earth

WIRE	CONT.
X119	Earth

WIRE	CONT.
X120	Earth

WIRE	CONT.
X121	Earth

WIRE	CONT.
X123	Earth

WIRE	CONT.
X124	Earth

WIRE	CONT.
X125	Earth

WIRE	CONT.
X127	Earth

WIRE	CONT.
X128	Earth

WIRE	CONT.
X129	Earth

WIRE	CONT.
X131	Earth

WIRE	CONT.
X132	Earth

WIRE	CONT.
X133	Earth

WIRE	CONT.
X135	Earth

WIRE	CONT.
X136	Earth

WIRE	CONT.
X137	Earth

WIRE	CONT.
X139	Earth

WIRE	CONT.
X140	Earth

WIRE	CONT.
X141	Earth

Explanation of designations:

- A1 - control module
- T1, T2, T3 - protection class current transformers, 5A secondary.
- K2, K3, K4 - overcurrent protection relays or inputs of MP protection relay
- Q1 - indoor switching module:
 - YA1, YA2, YA3 - magnetic actuator coils
 - S1-S6, S7-S12 - 52a/52b breaker contact
 - S13 - coil disconnect, driven by manual trip
 - R - resistor for interlock recognition
- Q2 - miniature circuit breaker. Recommended rating: 2A, class C or D. Supplied by customer.
- S21 - push button close. Supplied by customer.
- S22 - push button trip. Supplied by customer.

- Notes:
- The diagram is for mandatory control connection only, and is strictly for reference.
 - The diagram is for indoor switching modules of the following types: TNA_ISM15_MD_1(150), ISM15_MD_1(210), TNA_ISM15_HD_1(210) and TNA_ISM15_HD_1(275) with 2 installed auxiliary switch boards each.
 - The diagram is suitable for control modules of the type TNA_CM_16_2(220_2) only.
 - Auxiliary power supply range: (85...265)VDC/(85...265)VAC.
 - K1, K2, K3 - overcurrent protection relays or current inputs of MP protection relay.
 - T1, T2, T3 - protection class current transformers, 5A rated secondary current.
 - For further technical details see appropriate user / applications manuals.

DRAWN	A.Sergeyenko
CHECKED	T.Sergeyenko
APPROVED	S.Sims
FIRST ANGLE PROJECTION	

TAVRIDA ELECTRIC
Industrial Group North American Branch
1105 Cliveden Ave
Delta, BC V3M 6G9 Canada
Tel: 604.540.6600 Fax: 604.540.6604
www.tavrída-na.com

CUSTOMER:	ISM15_MD_1 + CM_16_2
PROJECT:	ISM15_MD_1/HD_1 + CM_16_2(220_2)
TITLE:	Schematic diagram

THIS DRAWING AND ALL INFORMATION CONTAINED HEREIN IS THE PROPERTY OF TAVRIDA ELECTRIC AND MAY NOT BE COPIED OR USED IN ANY WAY WITHOUT THE EXPRESSED WRITTEN CONSENT OF TAVRIDA ELECTRIC		
SIZE	DWG #:	REV
A3	ISM15_MD_1+CM_16_2(220_2)	1
SCALE	ID	SHEET 1 OF 2

REVISION HISTORY		DATE	APPROVED
ZON	REV	DESCRIPTION	
	1	Initial Check In	S.Sims

Notes:
 The CM_16 series control modules have three latching output relays in an SPDT configuration. Each relay can be factory programmed for one of three functions per the chart below. See the settings code label on the right side of the CM_16 module for as-shipped relay configuration.
 The relays will change state from unasserted to asserted based on the firmware logic as outlined in the chart below. Note that as the relays are latching types they will retain their last state (asserted or unasserted) after power loss and complete discharge of the module capacitor bank.

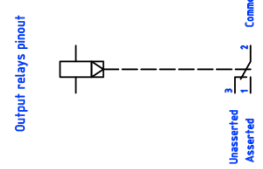
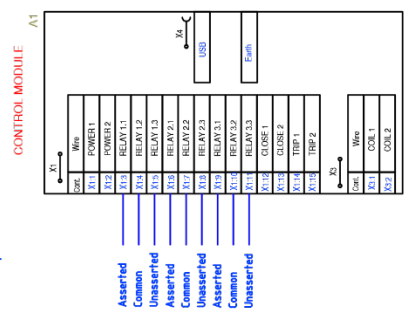

Relay programmed Function	Relay reaction to Control / Breaker Events			Ready to Close
	Breaker Open	Breaker Closed	Malfunction	
Breaker Position Indication (Indication whether breaker is open or closed)	Unasserted	Asserted	NO EFFECT	Loss of Supply NO EFFECT
Ready (Indication that the control module is ready to perform close operation)	NO EFFECT	NO EFFECT	Unasserted	Asserted
Malfunction (Indication that there is an error; all close operations blocked until corrected)	NO EFFECT	NO EFFECT	Asserted	Unasserted
UV Active (Indication that trip on loss of supply occurred. Available if UV is set "on")	NO EFFECT	NO EFFECT	NO EFFECT	NO EFFECT
Loss of Supply (Indication if control module has no power supply)	NO EFFECT	NO EFFECT	NO EFFECT	Asserted
Malfunction or Loss of Supply (Indication that there is an error or loss of power; all close operations blocked until corrected)	NO EFFECT	NO EFFECT	Asserted	Unasserted
Disabled (Relays disabled and will not change state for any event)	NO EFFECT	NO EFFECT	NO EFFECT	NO EFFECT

Note:
 x - asserted while power supply is lost but unasserted when power supply returns back on
 See Applications Manual for detailed description of "Malfunction", "Ready to Close" and "Trip on Loss of Supply" events.

DRAWN A. Sergeevko	CHECKED T. Sergeevko	APPROVED S. Sims	FIRST ANGLE PROJECTION
TAVRIDA ELECTRIC Industrial Group North American Branch 1105 Chiveden Ave Delta, BC V3M 6G9 Canada Tel: 604.540.6600 Fax: 604.540.6604 www.tavrada-ne.com		CUSTOMER: ISM15_MD_1 + CM_16_2(220_2)	PROJECT: ISM15_MD_1/HD_1 + CM_16_2(220_2)
		TITLE: Schematic diagram	SIZE: A2
		SCALE: 1	SHEET 2 OF 2

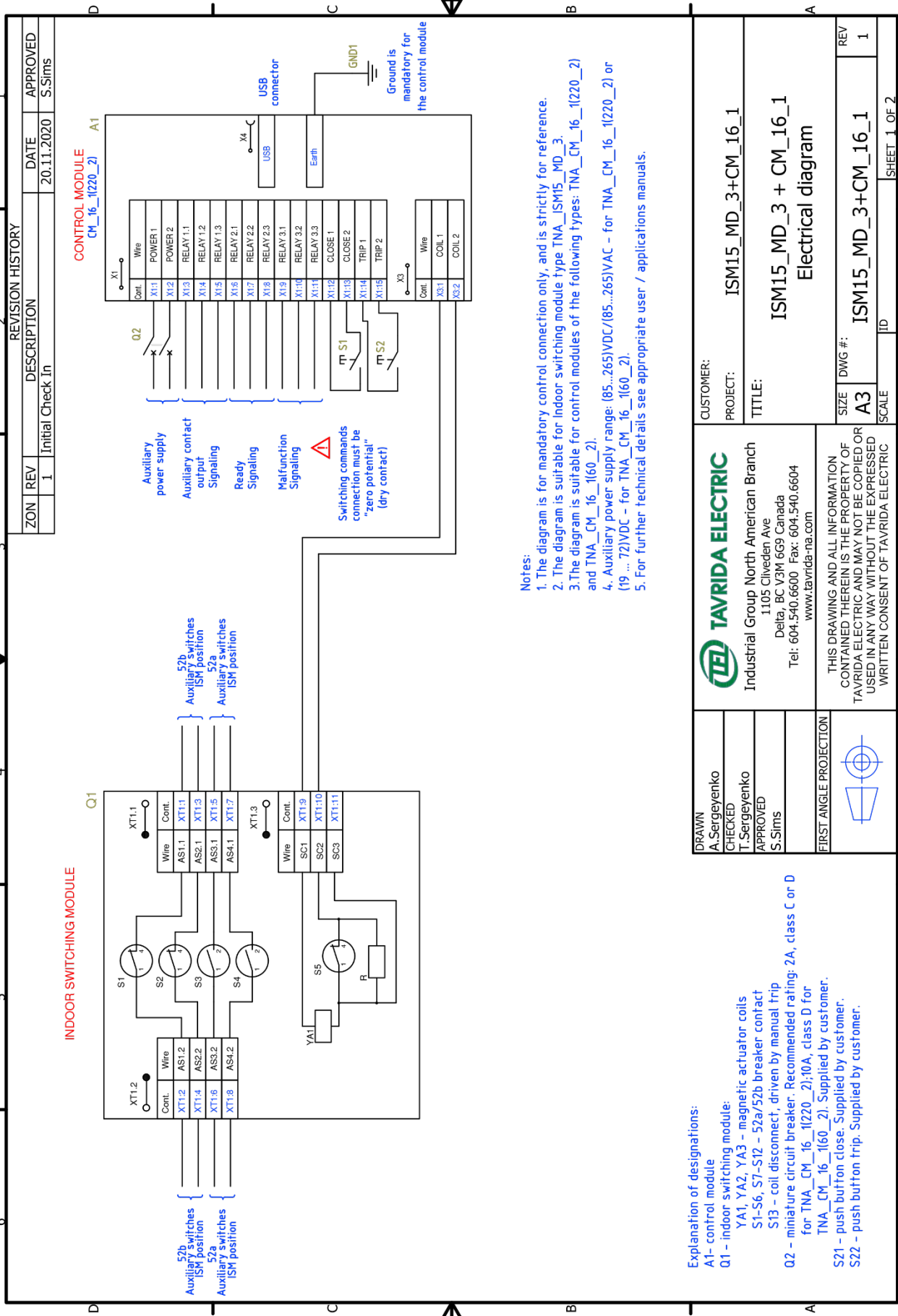

Explanation of designations:
 A1- control module
 Q1 - indoor switching module:
 YA1, YA2, YA3 - magnetic actuator coils
 S1-S6, S7-S12 - 52a/52b breaker contact
 S13 - coil disconnect, driven by manual trip
 Q2 - miniature circuit breaker. Recommended rating: 2A, class C or D for TNA_CM_16_1(220_2); 10A, class D for TNA_CM_16_1(60_2). Supplied by customer.
 S21 - push button close. Supplied by customer.
 S22 - push button trip. Supplied by customer.

DRAWN A.Sergeyenko	CUSTOMER: ISM15_MD_3+CM_16_1
CHECKED T.Sergeyenko	PROJECT:
APPROVED S.Sims	TITLE: ISM15_MD_3 + CM_16_1 Electrical diagram
FIRST ANGLE PROJECTION	SIZE DWG #: A3 ISM15_MD_3+CM_16_1
	SCALE
THIS DRAWING AND ALL INFORMATION CONTAINED THEREIN IS THE PROPERTY OF TAVRIDA ELECTRIC AND MAY NOT BE COPIED OR USED IN ANY WAY WITHOUT THE EXPRESSED WRITTEN CONSENT OF TAVRIDA ELECTRIC	
<p>TAVRIDA ELECTRIC Industrial Group North American Branch 1105 Cliveden Ave Delta, BC V3M 6G9 Canada Tel: 604.540.6600 Fax: 604.540.6604 www.tavrída-na.com</p>	
REVISION HISTORY ZON REV DESCRIPTION DATE APPROVED 1 Initial Check In 20.11.2020 S.Sims	SHEET 1 OF 2

REVISION HISTORY		DATE	APPROVED
ZON	REV	DESCRIPTION	
	1	Initial Check-in	S.Sims

Notes:
 The CM_16 series control modules have three latching output relays in an SPDT configuration. Each relay can be factory programmed for one of three functions per the chart below. See the settings code label on the right side of the CM_16 module for as-shipped relay configuration.
 The relays will change state from unasserted to asserted based on the firmware logic as outlined in the chart below. Note that as the relays are latching types they will retain their last state (asserted or unasserted) after power loss and complete discharge of the module capacitor bank.

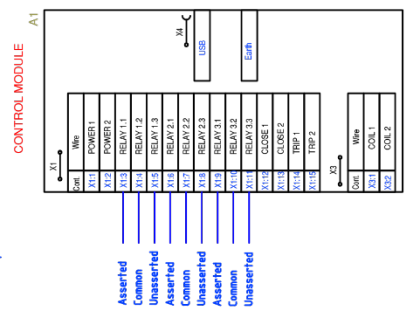

Relay programmed Function	Relay reaction to Control / Breaker Events			
	Breaker Open	Breaker Closed	Malfunction	Trip on Loss of Supply
Ready (Indication that the control module is ready to perform close operation)	Unasserted	Asserted	NO EFFECT	NO EFFECT
Breaker Position Indication (Indication whether breaker is open or closed)	Unasserted	Asserted	NO EFFECT	NO EFFECT
Ready	NO EFFECT	NO EFFECT	Unasserted	Asserted
(Indication that the control module is ready to perform close operation)	NO EFFECT	NO EFFECT	Unasserted	Asserted
Malfunction (Indication that there is an error; all close operations blocked until corrected)	NO EFFECT	NO EFFECT	Asserted	Unasserted
UV Active (Indication that trip on loss of supply occurred. Available if UV is set "on")	NO EFFECT	NO EFFECT	NO EFFECT	Asserted
Loss of Supply (Indication if control module has no power supply)	NO EFFECT	NO EFFECT	NO EFFECT	Asserted
Malfunction or Loss of Supply (Indication that there is an error or loss of power; all close operations blocked until corrected)	NO EFFECT	NO EFFECT	Asserted	Asserted
Disabled (Relays disabled and will not change state for any event)	NO EFFECT	NO EFFECT	NO EFFECT	NO EFFECT

Note:
 x - asserted while power supply is lost but unasserted when power supply returns back on
 See Applications Manual for detailed description of "Malfunction", "Ready to Close" and "Trip on Loss of Supply" events.

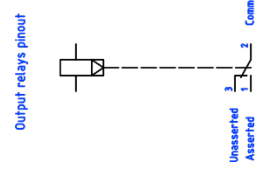

DRAWN A. Sergevniko	CHECKED T. Sergevniko	APPROVED S. Sims	FIRST ANGLE PROJECTION
TAVRIDA ELECTRIC Industrial Group North American Branch 1105 Cliveden Ave Delta, BC V3M 6G9 Canada Tel: 604.540.6600 Fax: 604.540.6604 www.tavrída-ne.com			CUSTOMER: ISM15_MD_3+CM_16_1 PROJECT: ISM15_MD_3 + CM_16_1 TITLE: Electrical diagram
THIS DRAWING AND ALL INFORMATION CONTAINED THEREIN IS THE PROPERTY OF TAVRIDA ELECTRIC AND MAY NOT BE COPIED OR USED IN ANY MANNER WITHOUT THE EXPRESS WRITTEN CONSENT OF TAVRIDA ELECTRIC			SIZE: A2 DWG #: ISM15_MD_3+CM_16_1 SCALE: 1:1 SHEET 2 OF 2

List of changes

Documents version	Change Date	Scope of change	Reason of change	Version author
1.0	25.08.2021	Document creation (based on TES manual v14)	-	Zhdi
2.0	03.08.2021	Operations counter added	Operations counter added	Zhdi
3.0	23.06.2022	Notation corrections and additions.	-	maryi
3.1	01.02.2024	Making edits	-	maryi

North America

Tavrida Electric North America Inc.
1105 Cliveden Ave.
Delta, BC V3M 6G9 Canada
2000 Tall Pines Drive., Suite 200, Largo, FL,
33771 USA
Phone: +1 (866) 551-8362
E-mail: info@tavrida-na.com

Brazil

Tavrida Electric do Brazil
Av. Ireneo da Silva Venâncio,199
GP04A - Protestantes
Votorantim / SP, Brazil
Phone: +55 (15) 3243-2555
Fax: +55 (15) 3243-4233
E-Mail: info@tavrida.com.br

South Africa

Tavrida Electric Africa (Pty) Ltd.
Unit 8, N12 Industrial Park,
188 Dr Vosloo Road, Bartlett,
Boksburg, 1459 South Africa
Phone: +27 11 9142199
Fax: +27 11 9142323
E-Mail: support@tavrida.co.za

Europe

Tavrida Electric GmbH
Im Leimen 14, 88069
Tettngang, Germany
Phone: +49 7542 94 678 51
Fax: +49 7542 94 678 61
E-mail: info@tavrida.de

Rest of the world

Tavrida Electric AG
Bahnhofstrasse 27, 6300
Zug, Switzerland
Phone: + 49 7542 9467851
Fax: +41 52 6302609
E-mail: TES_SM@tavrida.ch

This document is copyrighted and is intended for users and distributors of Tavrida Electric product. It contains information that is the intellectual property of Tavrida Electric and the document, or any part thereof, should not be copied or reproduced in any form without written permission from Tavrida Electric.

Tavrida Electric applies a policy of ongoing development and reserves the right to change product without notice. Tavrida Electric does not accept any responsibility for loss or damage incurred as a result of acting or refraining from action based on information in this document.